

SANITARY PRESSURE SUSTAINING VALVE PS163

DESCRIPTION

The ADCAPure PS163 is a series of inline direct acting diaphragm sensing pressure sustaining valves. These regulators, available with spring or dome-loading, are designed for use with clean steam, compressed air, water and other gases or liquids compatible with the construction materials and valve design.

MAIN FEATURES

Spring or dome-loaded.
Non-rising adjustment knob.
Compact inline design with clamped body.
FDA / USP Class VI compliant seals.
Completely machined from bar stock material, no castings or forgings are used.

STANDARD SURFACE FINISH

Internal wetted parts: $\leq 0,51$ micron Ra – SF1.
External: $\leq 0,76$ micron Ra – SF3.
Other surface conditions see IS PV20.00 E – Technical information.
Ultrasonic cleaning.

OPTIONS: Leakage line connection 1/8" (captured vent).
Different soft sealings for liquids and gases.
Gauge connection on body.
Top cap (adjustment screw with cover).
Dome-loaded version.

USE: Clean steam, compressed air, water and other gases and liquids compatible with the construction.

AVAILABLE MODELS: PS163.

SIZES: 1/2" to 2"; DN 15 to 50.

REGULATING RANGES: 0,8 to 1,5 bar; 1 to 3 bar; 1,5 to 5 bar.

CONNECTIONS: ASME BPE, DIN and ISO clamp ferrules or tube weld (ETO) ends.
Others on request.

PACKAGING: Assembling and packaging in a clean room certified according to ISO 14644-1.
The product is end capped and sealed with recyclable thermo-shrinkable plastic film, to avoid contamination.

INSTALLATION: Horizontal installation. See IMI – Installation and maintenance instructions.



LIMITING CONDITIONS	
Valve model	PS163
Body design conditions	PN 16
Maximum upstream pressure	8 bar
Minimum upstream pressure	0,8 bar
Maximum operating temperature *	180 °C

* With PTFE diaphragm and seals. Consult the manufacturer in case of other elastomer materials.

CE MARKING – GROUP 2 (PED – European Directive)	
PN 16	Category
1/2" to 2" – DN 15 to 50	SEP

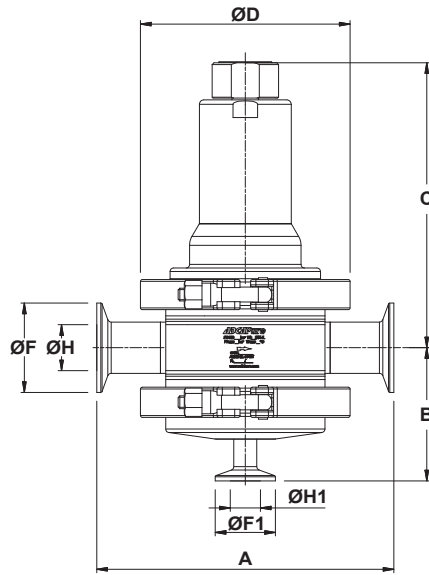
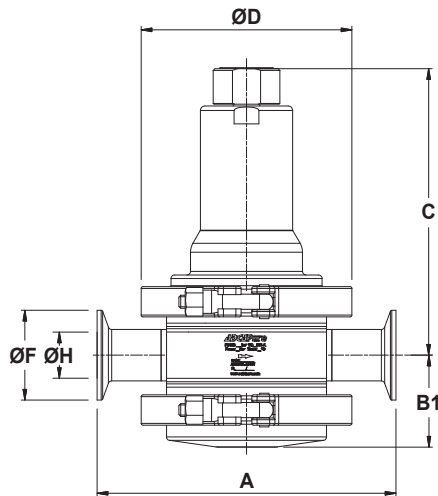

Optional bottom cover with drain connection

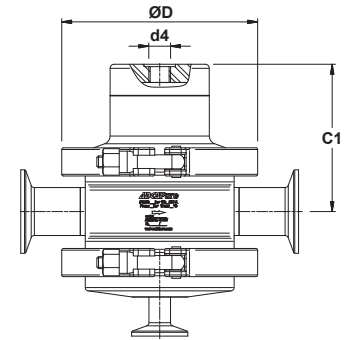

Optional dome-loaded version

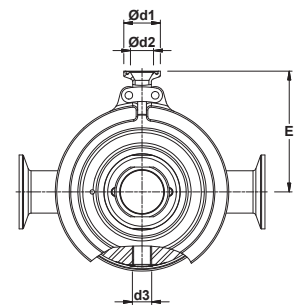

Optional pressure gauge connections

DIMENSIONS (mm) ASME BPE

SIZE	A	B	B1	C	C1	D	d1	d2	d3 *	d4 *	E	F	H	F1	H1	WGT. (kg)
1/2"	153	70	47	156	84	119	25	15,75	1/4"	1/4"	83	25	9,4	25	9,4	5
3/4"	153	74	51	160	88	119	25	15,75	1/4"	1/4"	83	25	15,75	25	9,4	5,6
1"	153	77	54	163	91	119	25	15,75	1/4"	1/4"	83	50,5	22,1	25	9,4	5,7
1 1/2"	170	95	71	204	124	134	25	15,75	1/4"	1/4"	96	50,5	34,8	25	9,4	9,8
2"	170	99	74	207	127	134	25	15,75	1/4"	1/4"	96	64	47,5	25	9,4	9,8

DIMENSIONS (mm) DIN

SIZE	A	B	B1	C	C1	D	d1	d2	d3 *	d4 *	E	F	H	F1	H1	WGT. (kg)
DN 15	153	74	51	160	88	119	25	15,75	1/4"	1/4"	83	34	16	34	10	5,6
DN 20	153	72	49	158	86	119	25	15,75	1/4"	1/4"	83	34	20	34	10	5,3
DN 25	168	75	52	161	89	119	25	15,75	1/4"	1/4"	83	50,5	26	34	10	5,6
DN 32	168	77	54	163	91	119	25	15,75	1/4"	1/4"	83	50,5	32	34	10	5,8
DN 40	185	94	70	202	122	134	25	15,75	1/4"	1/4"	96	50,5	38	34	10	9,5
DN 50	185	98	74	206	126	134	25	15,75	1/4"	1/4"	96	64	50	34	10	9,8

Remarks: Clamp ferrules according to DIN 32676-A; Tube weld (ETO) according to DIN 11866-A (DIN 11850-2).

DIMENSIONS (mm) DIN

SIZE	A	B	B1	C	C1	D	d1	d2	d3 *	d4 *	E	F	H	F1	H1	WGT. (kg)
DN 15	168	73	50	159	87	119	25	15,75	1/4"	1/4"	83	50,5	18,1	25	10,3	5,4
DN 20	168	76	53	162	90	119	25	15,75	1/4"	1/4"	83	50,5	23,7	25	10,3	5,6
DN 25	168	78	55	164	92	119	25	15,75	1/4"	1/4"	83	50,5	29,7	25	10,3	6
DN 32	185	93	69	202	122	134	25	15,75	1/4"	1/4"	96	64	38,4	25	10,3	9,6
DN 40	185	100	76	206	126	134	25	15,75	1/4"	1/4"	96	64	44,3	25	10,3	10

Remarks: Clamp ferrules according to DIN 32676-B; Tube weld (ETO) according to DIN 11866-B (ISO 1127).

* As standard, optional connections d3 and d4 are female threaded ISO 7 Rp.

FLOW RATE COEFFICIENTS (m³/h)

SIZE	ASME BPE					DIN						ISO				
	1/2"	3/4"	1"	1 1/2"	2"	DN 15	DN 20	DN 25	DN 32	DN 40	DN 50	DN 15	DN 20	DN 25	DN 32	DN 40
Kvs	1,3	3	4,2	7	13	2,1	3	4,2	7	7	13	2,1	4,2	4,2	7	7

MATERIALS

POS. N°	DESIGNATION	MATERIAL
1	Valve body	AISI 316L / 1.4404
2	Cover	AISI 316L / 1.4404
3	Intermediate flange	AISI 316L / 1.4404
3A	Clamp	AISI 316 / 1.4401
4	* Valve stem	AISI 316L / 1.4404
5	* Soft plug	** EPDM; PTFE; FPM
6	* Valve plug	AISI 316L / 1.4404
7	* Upper diaphragm	EPDM
8	* Lower diaphragm	PTFE (Gylon)
9	Diaphragm plate	AISI 316L / 1.4404
10	* O-ring	EPDM
11	Diaphragm plate	AISI 316L / 1.4404
12	Stem guide	AISI 316L / 1.4404
12A	Plain bearing	Bronze
13	Spring plate	AISI 316L / 1.4404
14	Nut	AISI 304 / 1.4301
15	Washer	AISI 304 / 1.4301
16	* Adjustment spring	AISI 302 / 1.4300
17	Top spring plate	AISI 316L / 1.4404
18	Retaining washer	Stainless steel A2-70
19	Adjustment nut	AISI 316L / 1.4404
20	Adjustment screw	Brass
21	O-ring	NBR
22	Bearing	Corrosion resistant steel
23	Shaft ring	Stainless steel
24	Cover nut	Plastic
25	* O-ring	NBR

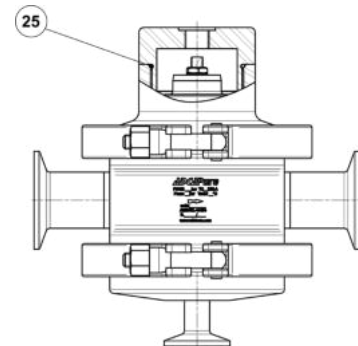
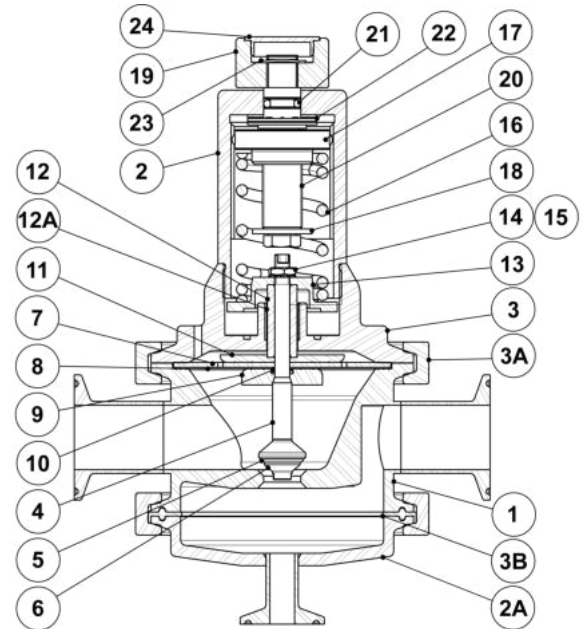

Optional dome-loaded version

* Available spare parts; ** Others according to fluid.

Remarks: FDA / USP Class VI seals certificate on request.

All valves have a serial number. In case of non-standard valves, this number must be supplied if spare parts are ordered.

OPTIONS

ADJUSTMENT SCREW WITH TOP CAP	PRESSURE GAUGE CONNECTION	LEAKAGE LINE CONNECTION

ORDERING CODES PS163

Valve model	PS63	1	4	1	T	M	I	X	X	X	DI	15	E
PS163 – AISI 316L / 1.4404 diaphragm sensing press. sustaining valve without drain	PS63												
PS163 – AISI 316L / 1.4404 diaphragm sensing press. sustaining valve with drain	PS6D												
Valve series													
Series 1		1											
Regulating range													
0,8 to 1,5 bar			4										
1 to 3 bar			5										
1,5 to 5 bar			6										
0,8 to 5 bar (dome-loaded) a)			A										
Flow rate coefficient													
Kvs 1,3 (only applicable to ASME BPE 1/2" size)				1									
Kvs 2,2 (applicable to sizes DIN DN 15 and ISO DN 15)				2									
Kvs 3 (applicable to sizes ASME BPE 3/4" and DIN DN 20)				3									
Kvs 4,2 (applicable to sizes ASME BPE 1", DIN DN 25 to DN 32 and ISO DN 20 to DN 25)				4									
Kvs 7 (applicable to sizes ASME BPE 1 1/2", DIN DN 40 and ISO DN 32 to DN 40)				6									
Kvs 13 (applicable to sizes ASME BPE 2" and DIN DN 50)				8									
Diaphragm													
PTFE (Gylon)					T								
EPDM (non-standard)					E								
Seat material b)													
Metal to metal (non-standard, except in ASME BPE 1/2" size)						M							
EPDM						E							
PTFE						T							
FPM / Viton (FDA approval only)						V							
Adjustment knob, top cap and captured vent													
Stainless steel adjustment knob							I						
Top cap (adjustment screw with cover)							T						
Stainless steel adjustment knob w/ diaphragm cover leakage connection in case of diaphragm failure							L						
Top cap (adjustment screw with cover) w/ diaphragm cover leakage connection in case of diaphragm failure							U						
Dome-loaded top c)							X						
Gauge port options													
Without gauge ports								X					
Tri-clamp gauge port on the left side (rel. to the flow direction) – downstream pressure								7					
Tri-clamp gauge port on the right side (rel. to the flow direction) – downstream pressure								6					
Tri-clamp gauge port on both sides – downstream pressure								5					
Threaded gauge port on the left side (rel. to the flow direction) – downstream pressure – ISO 7 Rp 1/4"								4					
Threaded gauge port on the right side (rel. to the flow direction) – downstream pressure – ISO 7 Rp 1/4"								3					
Threaded gauge port on both sides – downstream pressure – ISO 7 Rp 1/4"								2					
Threaded gauge port on the left side (rel. to the flow direction) – downstream pressure – 1/4" NPT								W					
Threaded gauge port on the right side (rel. to the flow direction) – downstream pressure – 1/4" NPT								Y					
Threaded gauge port on both sides – downstream pressure – 1/4" NPT								Z					
Surface finish d)													
Standard surface finish									X				
Mirror mechanical polished external surfaces (SF1)									P				
Electropolished internal wetted parts (SF5)									E				
Special features													
None										X			
Degreased for oxygen										O			
Pipe connections													
Clamp ferrule ASME BPE												D	
Clamp ferrule DIN (DIN 32676-A)												F	
Clamp ferrule ISO (DIN 32676-B)												E	
Tube weld (ETO) according to ASME BPE												DI	
Tube weld (ETO) according to DIN 11866-A (DIN 11850-2)												FI	
Tube weld (ETO) according to DIN 11866-B (ISO 1127)												EI	
Size													
1/2" or DN 15													15
3/4" or DN 20													20
1" or DN 25													25
DN 32													32
1 1/2" or DN 40													40
2" or DN 50													50
Special valves / Extras													
Full description or additional codes have to be added in case of a non-standard combination													E

a) The loading control pressure can be up to a maximum of 0,2 bar above the required upstream pressure; b) ASME BPE 1/2" size is only available with metal to metal sealing; c) Must be chosen in case of dome-loaded version; d) Consult IS PV20.00 – Technical information – for further details and other surface finish options.