

## HIGH PURITY BALL VALVES M3HP TRUE BORE (1/2" – 2" ASME BPE)

### DESCRIPTION

M3HP three piece body ball valves are isolating valves designed for use with clean steam, condensate and other gases and liquids used in high purity and aseptic processes.

The valve is not designed as a control valve and should only be used as an isolating valve, fully open or fully closed.

The product is mainly designed for the pharmaceutical, biotech, semiconductor, cosmetics, fine chemical, food and beverage industries.

### MAIN FEATURES

- True bore floating ball design.
- Completely made from solid bar stock material.
- Can be serviced without removal from pipeline.
- Bidirectional.
- Antistatic device.
- Anti blow out proof stem.
- Tube weld with loose body flanges (360° rotation after installation).
- ISO 5211 mounting (only sizes ≥1").

### STANDARD SURFACE FINISH

- Internal wetted parts: ≤ 0,51 micron Ra – SF1.
- External : ≤ 0,76 micron Ra – SF3.
- Other surface conditions see IS PV20.00 E – Technical information.
- Ultrasonic cleaning.

- OPTIONS:**
- Different sealing materials.
  - 1/2" and 3/4" ISO mounting with flange adapter.
  - Degreased for oxygen use.
  - Cavity filler.

- USE:** Clean steam, gases and liquids compatible with the construction.

- AVAILABLE MODELS:** M3HP – Complete bar stock construction.

- SIZES:** 1/2" to 2".

- CONNECTIONS:** According to ASME BPE.  
TC – Sanitary clamps.  
ETO – Extended tube orbital welding.  
TC / ETO – Combination.

- PACKAGING:** Assembling and packaging in a clean room certified according to ISO 14644-1.  
The product is end capped and sealed with recyclable thermo-shrinkable plastic film, to avoid contamination.

- INSTALLATION:** See IMI – Installation and maintenance instructions.

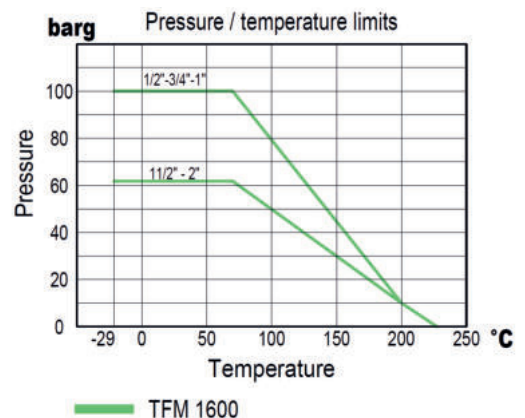

Note: Working pressure may be limited by the valve connections.

CE MARKING – GROUP 2 (PED – European Directive)		
PN63	PN100	Category
—	1/2" to 1"	SEP
1 1/2" to 2"	—	1 (CE marked)

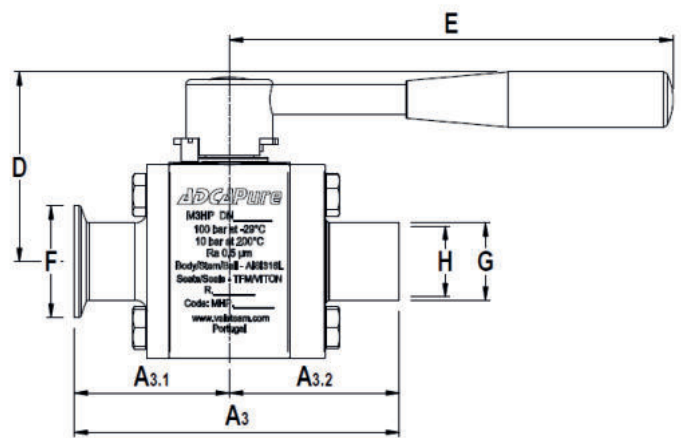
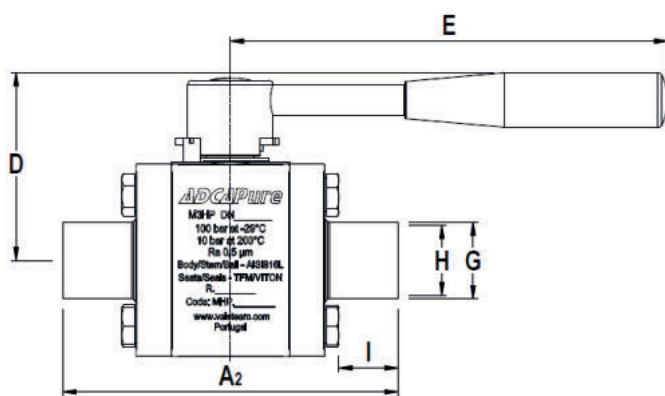
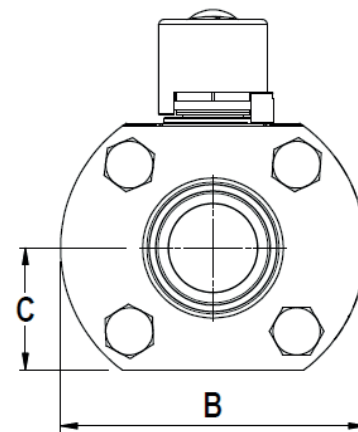
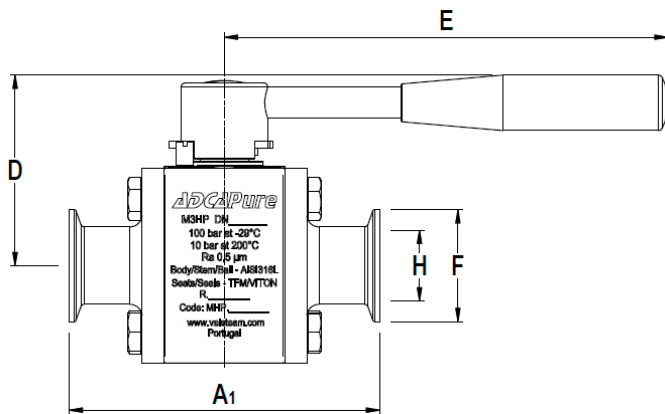

DIMENSIONS (mm) ASME BPE																
SIZE	A1	A2	A3	A3.1	A3.2	B	C	D	E	F	G	H	I	BALL PORT	ISO 5211	WGT. (kg)
1/2"	88,9	101,6	95,5	44	51,5	59	22	49	130	25	12,7	9,4	25	9,4	F03 *	0,9
3/4"	101,6	114,3	108	51	57	64	24,5	53	130	25	19,05	15,75	27	15,8	F03 *	1,4
1"	114,3	127	120,5	57	63,5	79	31	68	165	50,5	25,4	22,1	27	22,1	F04	2,3
1 1/2"	139,7	152,4	146,5	70	76,5	109	44	86	200	50,5	38,1	34,8	27	34,8	F05	5,3
2"	165,1	177,8	171,5	82,5	89	134	53	97	200	64	50,8	47,5	28	47,5	F05	8,5

\* Flange adapter is required, against extra price. See IS M3H.25 E Options and extras.

### Tube weld easy and quick installation - standard

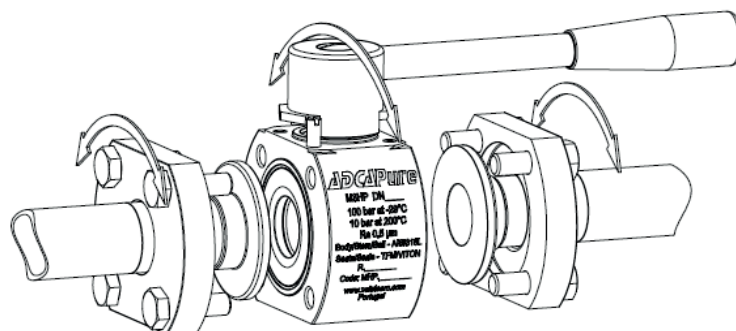

Loose body flanges make it possible to install the valve without the aligning of the welded end connections. After installation the valve can rotate 360° for the desired orientation.

**MATERIALS**

POS. N°	DESIGNATION	MATERIAL
1	Valve body	AISI 316L / 1.4404
2	TC end connection	AISI 316L / 1.4404
3	Tube weld end connection	AISI 316L / 1.4404
4	Flange	AISI 316L / 1.4404
5	Stem	AISI 316L / 1.4404
6	* Valve ball	AISI 316L / 1.4404
7	* Standard seat	TFM 1600
8	* Cavity filler seat	TFM 1600
9	* Body seal	PTFE
10	* Stem seals	TFM 1600
11	* Spacer	AISI 316 / 1.4401
12	Handle	AISI 304 / 1.4301
13	Handle end	Vinyl
13	Handle end (optional)	AISI 316L / 1.4404
14	* Spring washers	AISI 304 / 1.4301
15	Compression nut	AISI 304 / 1.4301
16	* Lock washer	AISI 304 / 1.4301
17	Fixing bolt	AISI 304 / 1.4301
18	Stop pin	AISI 304 / 1.4301
19	Handle stopper	AISI 304 / 1.4301
20	Washer	AISI 304 / 1.4301
21	Fixing screw	AISI 304 / 1.4301
22	Antistatic device	AISI 316 / 1.4401
23	O-ring	Viton

\* Available spare parts;

Remarks: FDA / USP Class VI seals certificate on request.

All valves have a serial number. In case of non-standard valves, this number must be supplied if spare parts are ordered.

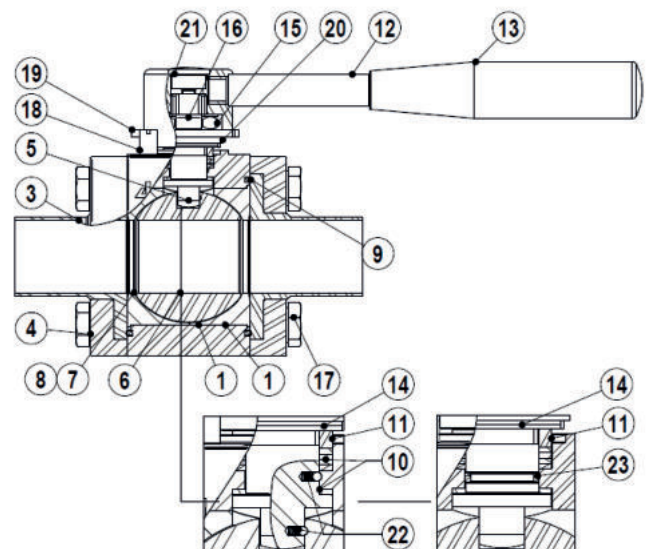
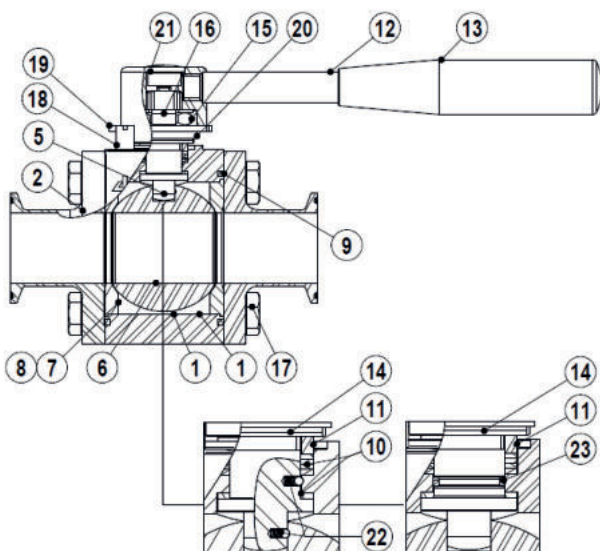
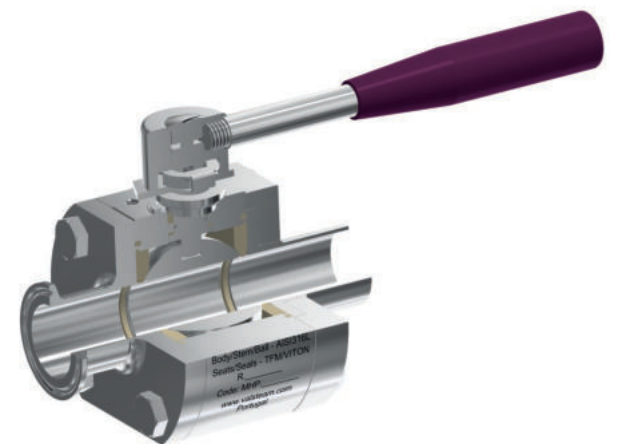
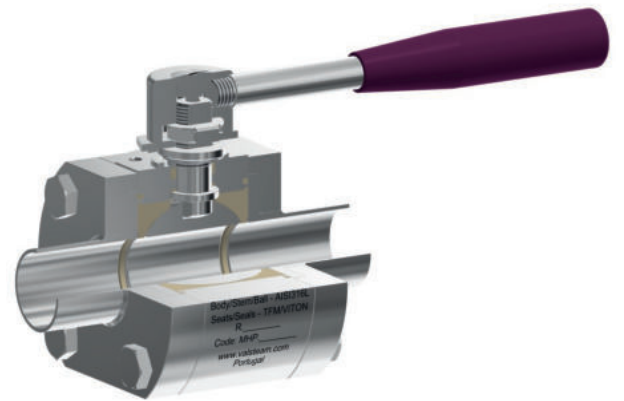
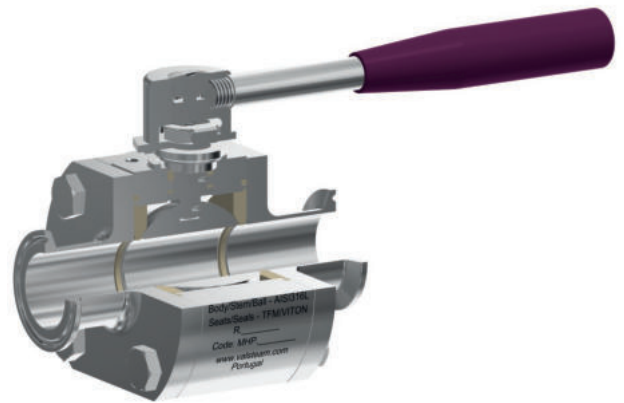

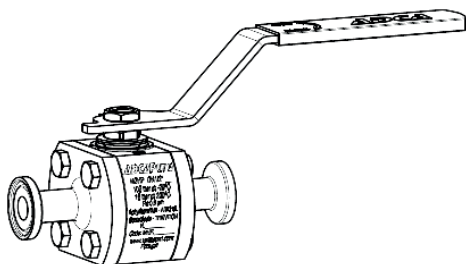

Flat lever handle with plastic cover.

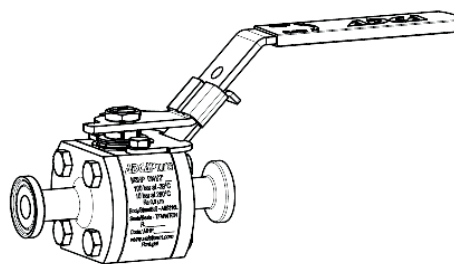

Flat lever handle with plastic cover and lockable system.

ORDERING CODES M3HP											
Valve model	MHP	X	X	X	F	X	X	CB	X	15	
M3HP 3 pieces ball valve - AISI 316L	MHP										
<b>Lever handle</b>											
Round lever handle stainless steel / plastic cover		X									
Round lever handle complete stainless steel		1									
Flat lever handle stainless steel / plastic cover		2									
Flat lever handle stainless steel / plastic cover w/ lockable system		3									
Bare stem		9									
<b>Material</b>											
AISI 316L / 1.4404			X								
<b>Seat design</b>											
Standard seats					X						
Cavity fillers					F						
<b>Seat material</b>											
TFM 1600					F						
<b>Surface finish a)</b>											
Standard surface finish						X					
Mirror mechanical polished external surfaces (SF1)						P					
Electropolished internal wetted parts (SF5)						E					
<b>Special features</b>											
None							X				
Oxygen cleaning							O				
<b>Pipe connections</b>											
TC – Sanitary clamps ASME BPE								CB			
ETO – Extended tube orbital welding ASME BPE (360° rotation design)								TB			
TC / ETO – Combination ASME BPE (360° rotation design)								CTB			
<b>Ball port</b>											
True bore (standard)									X		
Full bore									NA		
<b>Size</b>											
1/2"											15
3/4"											20
1"											25
1 1/2"											40
2"											50
<b>Special valves / Extras</b>											
Full description or additional codes have to be added in case of a non standard combination											E

a) Consult IS PV20.00 (Technical information) for further details and other surface finish options.

NA – Not available.