

HUMIDITY SEPARATORS Clean Steam Centrifugal Separator S10HV

DESCRIPTION

When wet steam is used in sterilization, moisture in suspension reduces the heat transfer efficiency, and the validity of the sterilization process can be compromised.

S10HV series centrifugal separators remove moisture from steam pipelines. Steam passes through the separator and as a result of centrifugal forces, impact and swirling effects, the particles with a heavier specific gravity are separated, such as water droplets and moisture in suspension.

The condensate collected at the bottom of the separator must be automatically drained by a suitable steam trap.

MAIN FEATURES

316L stainless steel construction.

No moving parts.

Self draining design.

STANDARD SURFACE FINISH

Internal wetted parts: $\leq 0,51$ micron Ra – SF1.

External: Satin bead blast finish – 1,6 micron Ra.

Other surface conditions see IS PV20.00 E – Technical information.

OPTIONS: Different kinds of connections and dimensions.

USE: Steam, compressed air and other gases (Group 2).

AVAILABLE MODELS: S10HV – horizontal inlet, vertical outlet.

SIZES: 1/2" to 2".

CONNECTIONS: ASME BPE clamp ferrules.
Others on request.

PACKAGING: Assembling and packaging in a clean room certified according to ISO 14644-1.
The product is end capped and sealed with recyclable thermo-shrinkable plastic film, to avoid contamination.

INSTALLATION: Always with the condensate discharge pointing downwards.
See IMI – Installation and maintenance instructions.

HOW TO SELECT: Generally, in an existing plant it is advisable to fit a separator with the same size of the pipe line. Pressure drop is normally negligible. For approximate pressure drop calculation, consult manufacturer.



BODY LIMITING CONDITIONS	
ALLOWABLE PRESSURE	RELATED TEMPERATURE
10 bar	50 °C
8 bar *	175 °C
7,4 bar	200 °C

* PMO – Max. operating pressure for saturated steam.
Minimum operating temperature: -10 °C.
Design code: AD-Merkblatt.

CE MARKING – GROUP 2 (PED – European Directive)	
PN 10	Category
1/2" to 2"	SEP

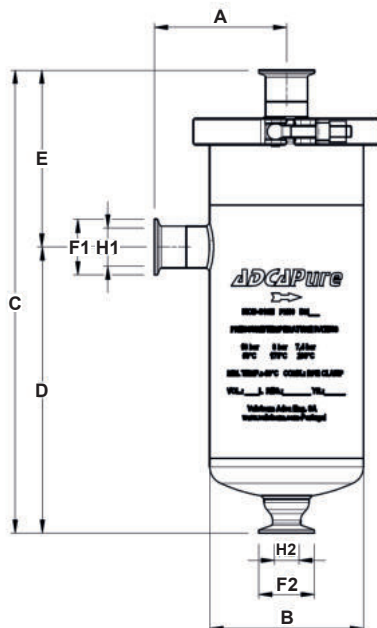

DIMENSIONS (mm)											
SIZE	A	B	C	D	E	F1	F2	H1	H2	VOL. (dm ³)	WEIGHT (kg)
1/2"	105	114	326	195	131	25	50,5	9,4	22,1	2,84	3,8
3/4"	105	114	326	195	131	25	50,5	15,75	22,1	2,87	3,9
1"	105	114	341	210	131	50,5	50,5	22,1	22,1	2,9	4,2
1 1/2"	120	140	421	260	161	50,5	50,5	34,8	22,1	5,82	7,25
2"	120	140	421	260	161	64	50,5	47,5	22,1	5,93	7,28

MATERIALS		
POS. N°	DESIGNATION	MATERIAL
1	Body	AISI 316L / 1.4404
2	Cover	AISI 316L / 1.4404
3	* Clamp	AISI 316L / 1.4404
4	* Seal	Viton
5	Internals	AISI 316L / 1.4404

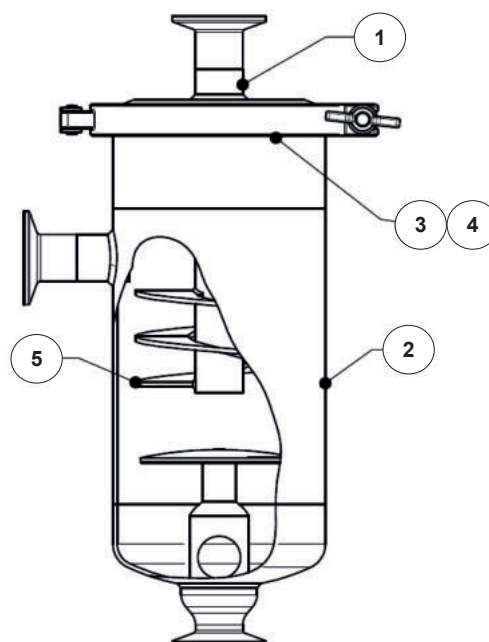

* Available spare parts.
 EN 10204 3.1 certificate available if requested along with the order.
 Remarks: FDA / USP Class VI seals certificate on request.
 All separators have a serial number. In case of non-standard separators, this number must be supplied if spare parts are ordered.