

SANITARY TANK BLANKETING REGULATORS BKV2

DESCRIPTION

Tank blanketing valves are commonly used in tank storage systems to prevent and protect against explosions (avoiding flammable liquids being vented from the vessel), to control product contamination against external air that may fill the vapour space, to reduce evaporation losses (consequently, production losses), to reduce internal corrosion (caused by air and moisture) and to prevent vacuum condition.

The blanketing process consists in covering the stored medium, usually a liquid, with a gas (normally N₂).

MAIN FEATURES

Compact design.
Non-rising adjustment knob.

STANDARD SURFACE FINISH

Body and internal wetted parts: ≤ 0,51 micron Ra – SF1.
Body external: ≤ 0,76 micron Ra – SF3.
Cover: internal machined; external as casted.
Other surface conditions see IS PV20.00 E – Technical information.
Ultrasonic cleaning.

OPTIONS:

- Diaphragm leakage line connection.
- Gauge connection on body.
- External pulse line (recommended for low set pressures < 10 mbar or high flow).
- Dome loaded version.
- Blanketing with vacuum.
- Top cap (adjustment screw with cover).
- Hastelloy wetted parts.
- ATEX  version.

USE: Compressed air, nitrogen and other gases compatible with the construction.

AVAILABLE MODELS: BKV2 – low pressure venting valve.

SIZES: 1"; DN 25.

REGULATING RANGES: 5 – 10 mbar; 10 – 50 mbar; 20 – 200 mbar; 50 – 500 mbar; 5 to 4000 mbar (dome loaded).

CONNECTIONS: ASME BPE, DIN and ISO clamp ferrules.
Flanged EN 1092-1 PN 16.
Others on request.

PACKAGING: Assembling and packaging in a clean room certified according to ISO 14644-1.
The product is end capped and sealed with recyclable thermo-shrinkable plastic film, to avoid contamination.

INSTALLATION: Vertical installation recommended, to allow drainage, or horizontal as close to the process as possible in order to prevent long pipe sections and flow restrictions. See IMI – Installation and maintenance instructions.

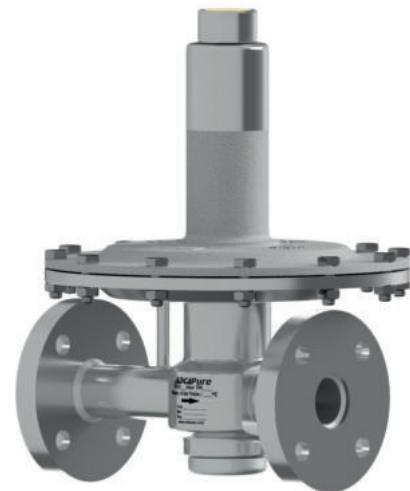
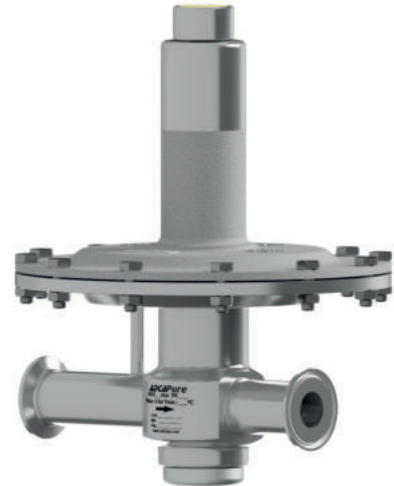

CE MARKING – GROUP 2 (PED – European Directive)

PN 16	Category
1" – DN 25	SEP

CE MARKING – ATEX VERSION (ATEX – European Directive)

PN 16	Category
1" – DN 25	Ex h IIB T6...T3 Gb

AIR CAPACITIES (Nm³/h)
Seat Ø 21 mm

SIZE	SET PRESSURE	INLET PRESSURE (mbar)					
		10	20	40	100	200	500
1" – DN 25	25% Overpressure	5,3	11,8	18	31	52	105
1" – DN 25	50% Overpressure	7,2	14,5	26	40	66	125
1" – DN 25	75% Overpressure	8,3	17	30	47	82	136
1" – DN 25	100% Overpressure	9,8	18	36	52	91	148

DIMENSIONS (mm) ASME BPE

SIZE	A	B	C	D	F	H	d1	d2	WEIGHT (kg)
1"	210	49	244	230	50,5	22,1	25	15,75	8,5

DIMENSIONS (mm) DIN

SIZE	A	B	C	D	F	H	d1	d2	WEIGHT (kg)
DN 25	210	49	244	230	50,5	26	25	15,75	8,5

Remark: Clamp ferrules according to DIN 32676-A.

DIMENSIONS (mm) ISO

SIZE	A	B	C	D	F	H	d1	d2	WEIGHT (kg)
DN 25	210	49	244	230	50,5	29,7	25	15,75	8,5

Remark: Clamp ferrules according to DIN 32676-B.

DIMENSIONS (mm) FLANGED

SIZE	A	B	C	D	d1	d2	WEIGHT (kg)
DN 25	210	49	244	230	25	15,75	10,6

LIMITING CONDITIONS

Valve model	BKV2
Body design conditions	PN 16
Maximum operating pressure	6 bar
Maximum upstream pressure *	500 mbar
Minimum upstream pressure	5 mbar
Maximum design temperature **	130 °C

* 4000 mbar with dome load;

** Others on request.

Warning: Blanketing valves are not substitute for safety valves or vacuum relief valves.

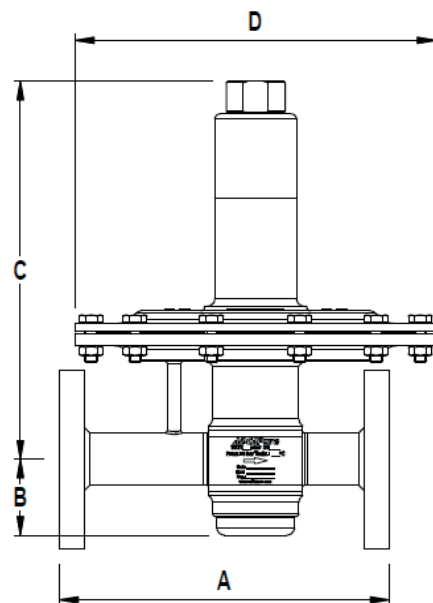
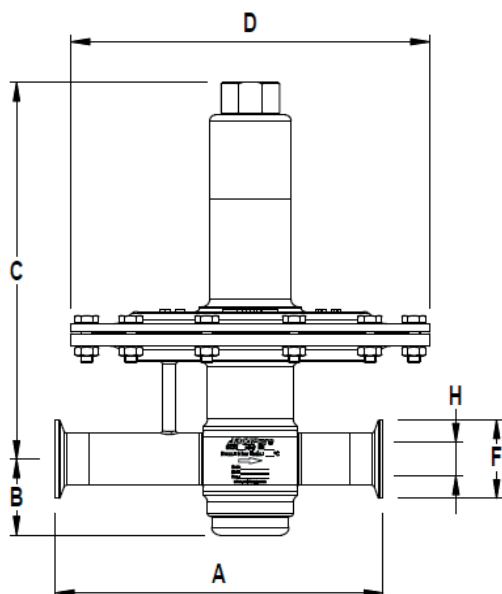
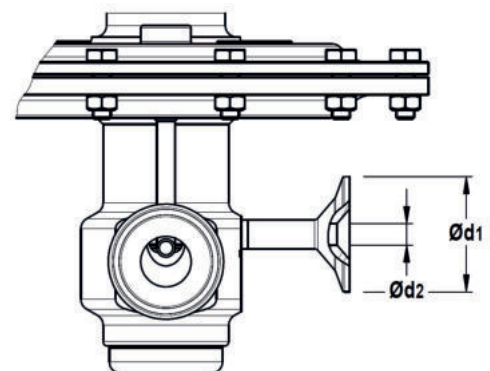

MATERIALS

POS. N°	DESIGNATION	MATERIAL
1	Valve body	AISI 316L / 1.4404
		Hastelloy C22 / 2.4602
2	Diaphragm top cover	A351 CF3M / 1.4409
2A	Diaphragm bottom cover	AISI 316L / 1.4404
		Hastelloy C22 / 2.4602
3	Seat cover	AISI 316L / 1.4404
		Hastelloy C22 / 2.4602
4	* O-ring	EPDM
5	Plug disc	AISI 316L / 1.4404
		Hastelloy C22 / 2.4602
6	* Valve head	AISI 316L / 1.4404
		Hastelloy C22 / 2.4602
7	* O-ring	EPDM
8	Seat	AISI 316L / 1.4404
		Hastelloy C22 / 2.4602
9	* O-ring	EPDM
10	Stem	AISI 316L / 1.4404
		Hastelloy C22 / 2.4602
11	Stem guide	PTFE
12	Retaining ring	Stainless steel A2-70
		Hastelloy C22 / 2.4602
13	Diaphragm plate	AISI 316L / 1.4404
		Hastelloy C22 / 2.4602
14	* O-ring	EPDM
15	Bolts	Stainless steel A2-70
16	Nuts	Stainless steel A2-70
17	Spring cover	AISI 316L / 1.4404
18	* Lower diaphragm	PTFE (Gylon)
19	* Upper diaphragm	EPDM
20	Diaphragm plate	AISI 316L / 1.4404
21	Nut	Stainless steel A2-70
22	Washer	AISI 316 / 1.4401
23	Lower spring guide	AISI 316L / 1.4404
24	* Adjustment spring	AISI 302 / 1.4300
25	Top spring plate	AISI 316L / 1.4404
26	Adjustment screw	Brass
27	Bearing	Corrosion resistant steel
28	* O-ring	NBR
29	Adjustment nut	AISI 316L / 1.4404
30	Ext. bowed shaft ring	Stainless steel
31	Cover nut	Plastic

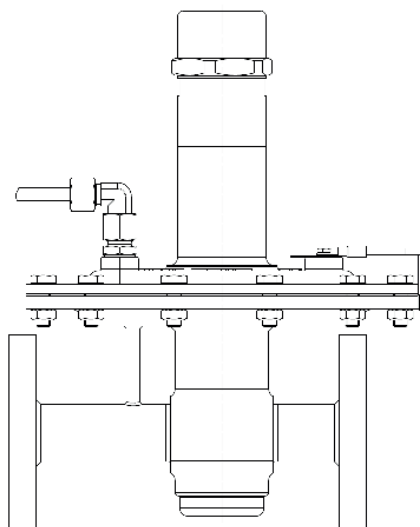
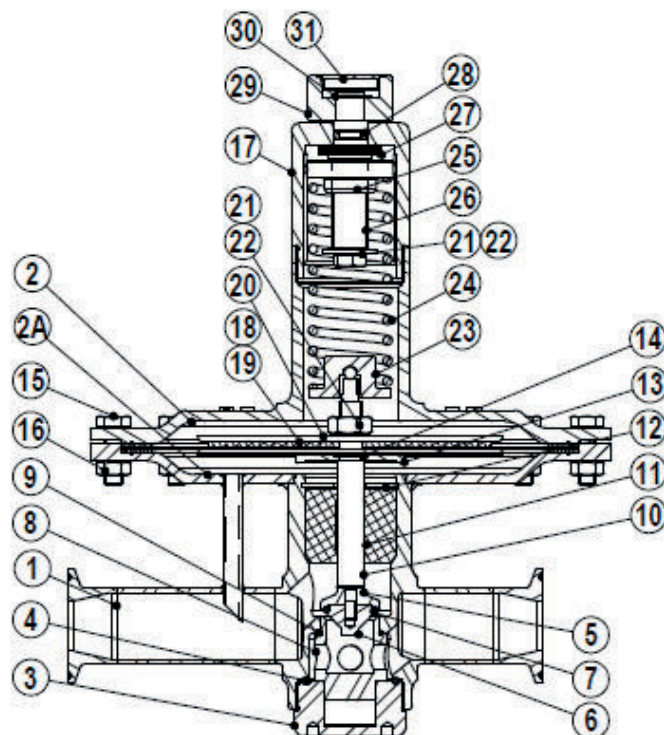

ATEX compliant version

* Available spare parts.

FDA / USP Class VI seals certificate on request.

All valves have a serial number. In case of non standard valves, this number must be supplied if spare parts are ordered.

OPTIONS

PRESSURE GAUGE CONNECTION	ADJUSTMENT SCREW WITH COVER	LEAKAGE LINE CONNECTION (1/4")

TYPICAL INSTALLATION

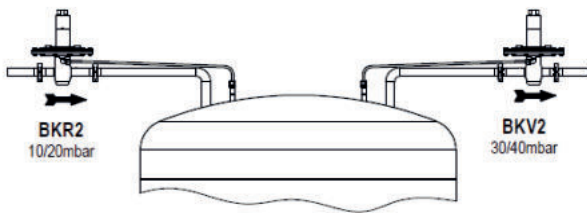

Blanketing with overpressure

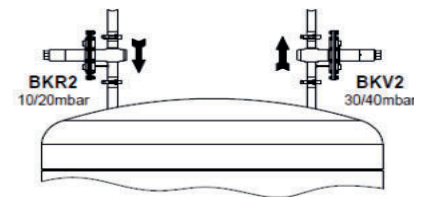

ORDERING CODES BKV2

Valve model	BV	A	2	T	E	I	X	X	X	0	D	25	E
BKV2 – AISI 316L / 1.4404 blanketing low pressure vent valve	BV												
BKV2 – Hastelloy C22 / 2.4602 blanketing low pressure vent valve	BVH												
Regulating range													
5 to 4000 mbar (dome loaded)	A												
5 to 10 mbar	0												
10 to 50 mbar	1												
20 to 200 mbar	2												
50 to 500 mbar	3												
Valve seat orifice													
Seat diameter 21 mm		2											
Diaphragm													
PTFE (Gylon)				T									
EPDM (non-standard)				E									
Valve head													
EPDM					E								
Adjustment knob, top cap and captured vent													
Stainless steel adjustment knob						I							
Top cap (adjustment screw with cover)						T							
Stainless steel adjustment knob w/ diaphragm cover leakage connection in case of diaphragm failure						L							
Top cap (adjustment screw with cover) w/ diaphragm cover leakage connection in case of diaphragm failure a)						U							
Gauge port options													
Without gauge ports							X						
Tri-clamp gauge port on the left side (rel. to the flow direction) – downstream pressure							7						
Tri-clamp gauge port on the right side (rel. to the flow direction) – downstream pressure							6						
Tri-clamp gauge port on both sides – downstream pressure							5						
Threaded gauge port on the left side (rel. to the flow direction) – downstream pressure – ISO 7 Rp 1/4"							4						
Threaded gauge port on the right side (rel. to the flow direction) – downstream pressure – ISO 7 Rp 1/4"							3						
Threaded gauge port on both sides – downstream pressure – ISO 7 Rp 1/4"							2						
Threaded gauge port on the left side (rel. to the flow direction) – downstream pressure – 1/4" NPT							W						
Threaded gauge port on the right side (rel. to the flow direction) – downstream pressure – 1/4" NPT							Y						
Threaded gauge port on both sides – downstream pressure – 1/4" NPT							Z						
Surface finish b)													
Standard surface finish								X					
Mirror mechanical polished external surfaces (SF1)								P					
Electropolished internal wetted parts (SF5)								E					
Special features													
None									X				
External pulse line													
Internal pulse orifice (standard)										0			
External pulse line connection 1/4"										1			
Pipe connection													
Clamp ferrule ASME BPE												D	
Clamp ferrule DIN (DIN 32676-A)												F	
Clamp ferrule ISO (DIN 32676-B)												E	
Flanged EN 1092-1 PN 16												L	
Size													
1" or DN 25													25
Special valves / Extras													
ATEX compliant version													EX
Full description or additional codes have to be added in case of non-standard combination													E

a) This option must be chosen in case of ATEX compliant version; b) Consult IS PV20.00 for further details and other surface finish options.