

**SANITARY PRESSURE REDUCING VALVE
P130C**

DESCRIPTION

The ADCA P130C series direct acting, spring-loaded diaphragm sensing pressure reducing valves are designed for use with clean air, nitrogen, carbon dioxide, oxygen, argon and other gases or liquids compatible with the construction materials and valve design.

This valve is specifically designed for the high purity gas systems found in the pharmaceutical, cosmetic, fine chemical and food & beverage processes.

MAIN FEATURES

- Compact design.
- Completely machined from 316L stainless steel bar stock, no castings or forgings are used.
- FDA / USP Class VI compliant seals.
- Non-rising adjustment knob.
- Clamped body.

STANDARD SURFACE FINISH

- Internal wetted parts: ≤ 0,51 micron Ra – SF1.
- External: ≤ 0,76 micron Ra – SF3.
- Other surface conditions see IS PV20.00 E – Technical information.
- Ultrasonic cleaning.

- OPTIONS:**
- Self relieving.
 - Leakage line connection 1/8" (captured vent).
 - Gauge connection on body.
 - Different soft valves for liquids and gases.
 - Wall mounting.

- USE:**
- Clean air, nitrogen, carbon dioxide, oxygen, argon and other gases or liquids compatible with the construction.

- AVAILABLE MODELS:**
- P130C – clamped body.

- SIZES:**
- 1/2" to 1"; DN 08 to DN 25.

- REGULATING RANGES:**
- 0,2 – 1,5 bar; 0,3 – 3 bar; 2 – 8 bar.

- CONNECTIONS:**
- ASME BPE, DIN and ISO clamp ferrules or tube weld (ETO) ends.
Others on request.

- PACKAGING:**
- Assembling and packaging in a clean room certified according to ISO 14644-1.
The product is end capped and sealed with recyclable thermo-shrinkable plastic film, to avoid contamination.

- INSTALLATION:**
- Horizontal installation recommended.
See IMI – Installation and maintenance instructions.



LIMITING CONDITIONS	
Valve model	P130C
Body design conditions	PN 16
Maximum upstream pressure	16 bar
Maximum downstream pressure	8 bar
Minimum downstream pressure	0,2 bar
Maximum design temperature *	150 °C

* Others on request.

CE MARKING – GROUP 2 (PED – European Directive)	
PN 16	Category
1/2" to 1" – DN 08 to DN 25	SEP

FLOW RATE COEFFICIENTS (m³/h) *

SIZE	ASME BPE		DIN		ISO	
	1/2"	3/4" to 1"	DN 10	DN 15 to DN 25	DN 08	DN 10 to DN 20
Kvs	1,7	3	1,7	3	1,7	3

* Reduced Kvs on request.

DIMENSIONS (mm) ASME BPE

SIZE	A	B	C	D	d1	d2	E	F	H	WEIGHT (kg) *
1/2"	130	36,5	130	90	25	15,75	75	25	9,4	2,9
3/4"	130	36,5	130	90	25	15,75	80	25	15,75	2,9
1"	130	36,5	130	90	25	15,75	80	50,5	22,1	3,4

* Valves with nylon adjustment knob weigh 0,3 kg less.

DIMENSIONS (mm) DIN

SIZE	A	B	C	D	d1	d2	E	F	H	WEIGHT (kg) *
DN 10	120	36,5	130	90	25	15,75	75	34	10	2,9
DN 15	120	36,5	130	90	25	15,75	75	34	16	3
DN 20	120	36,5	130	90	25	15,75	80	34	20	3,1
DN 25	120	38,5	128	90	25	15,75	80	50,5	26	3,4

* Valves with nylon adjustment knob weigh 0,3 kg less.

Remarks: Clamp ferrules according to DIN 32676-A; Tube weld (ETO) according to DIN 11866-A (DIN 11850-2).

DIMENSIONS (mm) ISO

SIZE	A	B	C	D	d1	d2	E	F	H	WEIGHT (kg) *
DN 08	120	36,5	130	90	25	15,75	75	25	10,3	2,9
DN 10	120	36,5	130	90	25	15,75	80	25	14	3
DN 15	120	36,5	130	90	25	15,75	80	50,5	18,1	3,2
DN 20	120	38,5	128	90	25	15,75	80	50,5	23,7	3,4

* Valves with nylon adjustment knob weigh 0,3 kg less.

Remarks: Clamp ferrules according to DIN 32676-B; Tube weld (ETO) according to DIN 11866-B (ISO 1127).

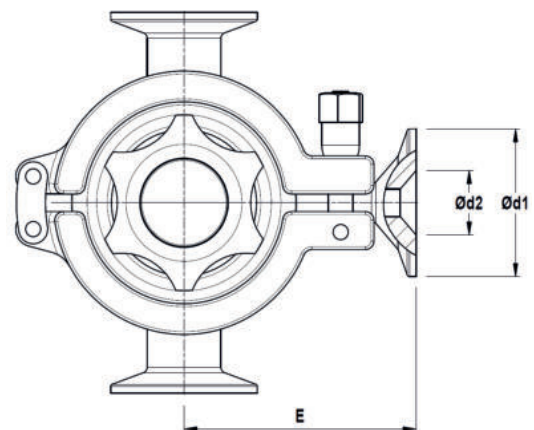
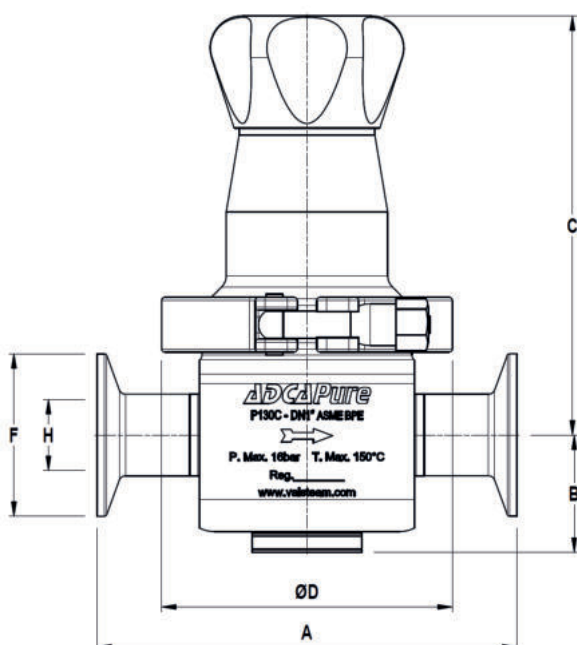

Optional pressure gauge connection.

MATERIALS

POS. N°	DESIGNATION	MATERIAL
1	Valve body	AISI 316L / 1.4404
2	Cover	AISI 316L / 1.4404
3	Seat cover	AISI 316L / 1.4404
4	* O-ring	Viton ; EPDM
5	* Piston	AISI 316L / 1.4404
6	* Valve head	AISI 316L / 1.4404 ; Viton ; PTFE
7	* Valve spring	AISI 316 / 1.4401 electropolished
9	Pusher disc	AISI 316L / 1.4404
10	* Lower diaphragm	PTFE (Gylon)
11	* Upper diaphragm	EPDM
13	Spring plate	AISI 304 / 1.4301
14	Nut	Stainless steel A2-70
15	* Adjustment spring	AISI 302 / 1.4300
16	Spring plate	AISI 316 / 1.4401
17	Adjustment screw	Brass
18	Retaining washer	Stainless steel A2-70
19	Adjustment knob	AISI 316L / 1.4404 Nylon
20	O-ring	NBR
21	** O-ring	EPDM
22	Bearing	Corrosion resistant steel
23	Ext. bowed shaft ring	Stainless steel
24	Cover nut	Plastic
25	Captured vent ring	AISI 316L / 1.4404
26	Clamp	AISI 316L / 1.4404

* Available spare parts ; ** If applicable.

Remarks: FDA / USP Class VI seals certificate on request.

All valves have a serial number. In case of non-standard valves, this number must be supplied if spare parts are ordered.

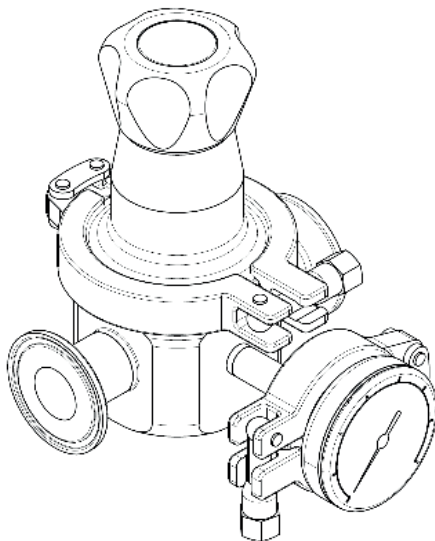
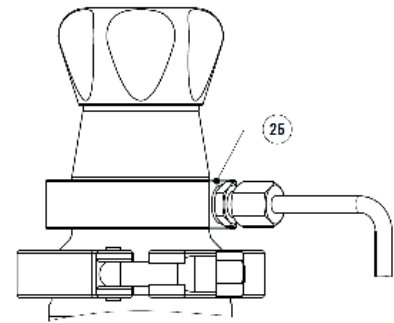
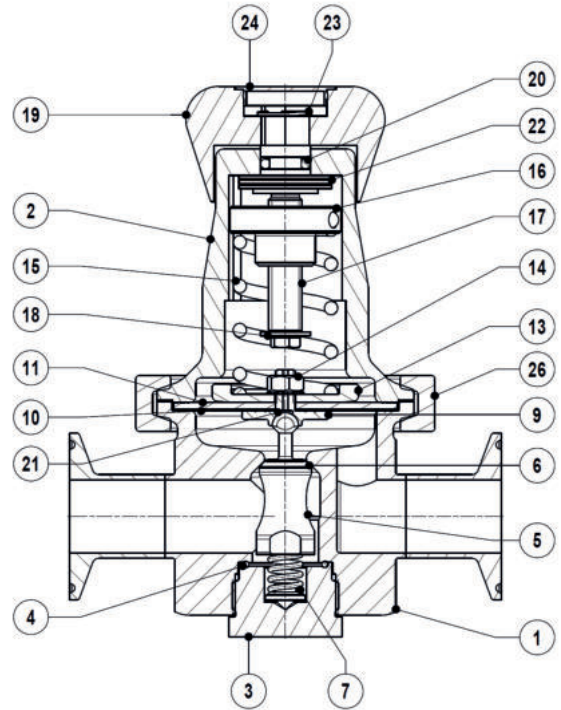

Optional pressure gauge connection.

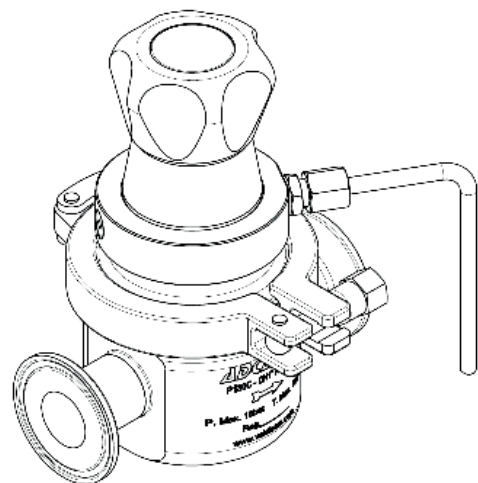

Optional 1/8" captured vent and/or leakage connection.
 (Compression fitting and tube not included).

ORDERING CODES P130C

Valve model	P13C	1	3	T	M	X	I	X	X	X	DI	15		
P130C – AISI 316L / 1.4404 diaphragm sensing pressure reducing valve	P13C													
Regulating range														
0,2 to 1,5 bar		1												
0,3 to 3 bar		2												
2 to 8 bar		3												
Flow rate coefficient														
Kvs 0,6		1												
Kvs 1		2												
Kvs 1,7		3												
Kvs 3 (not applicable to sizes 1/2" ASME BPE, DIN DN 10 and ISO DN 08)		6												
Diaphragm														
PTFE (Gylon)				T										
EPDM (non-standard)				E										
Seat material														
Metal to metal (non-standard)					M									
EPDM					E									
PTFE					T									
FPM / Viton					V									
Relieving														
Non-relieving						X								
Relieving (only for non-dangerous gases)						R								
Relieving with captured vent						L								
Adjustment knob and top cap														
Stainless steel adjustment knob							I							
Nylon adjustment knob							P							
Top cap (adjustment screw with cover)							T							
Gauge port options														
Without gauge ports								X						
Tri-clamp gauge port on the left side (rel. to the flow direction) – downstream pressure									7					
Tri-clamp gauge port on the right side (rel. to the flow direction) – downstream pressure										6				
Tri-clamp gauge port on both sides – downstream pressure											5			
Threaded gauge port on the left side (rel. to the flow direction) – downstream pressure – ISO 7 Rp 1/4"												4		
Threaded gauge port on the right side (rel. to the flow direction) – downstream pressure – ISO 7 Rp 1/4"													3	
Threaded gauge port on both sides – downstream pressure – ISO 7 Rp 1/4"														2
Threaded gauge port on the left side (rel. to the flow direction) – downstream pressure – 1/4" NPT														W
Threaded gauge port on the right side (rel. to the flow direction) – downstream pressure – 1/4" NPT														Y
Threaded gauge port on both sides – downstream pressure – 1/4" NPT														Z
Surface finish a)														
Standard surface finish											X			
Mirror mechanical polished external surfaces (SF1)												P		
Electropolished internal wetted parts (SF5)												E		
Special features														
None												X		
Degreased for oxygen												O		
Pipe connection														
Clamp ferrule ASME BPE												D		
Clamp ferrule DIN (DIN 32676-A)												F		
Clamp ferrule ISO (DIN 32676-B)												E		
Tube weld (ETO) according to ASME BPE												DI		
Tube weld (ETO) according to DIN 11866-A (DIN 11850-2)												FI		
Tube weld (ETO) according to DIN 11866-B (ISO 1127)												EI		
Size														
DN 08												08		
DN 10												10		
1/2" or DN 15												15		
3/4" or DN 20												20		
1" or DN 25												25		
Special valves / Extras														
Full description or additional codes have to be added in case of non-standard combination												E		

a) Consult IS PV20.00 for further details and other surface finish options.