

SANITARY PRESSURE REDUCING VALVE P130K

DESCRIPTION

The ADCA P130K series direct acting, spring-loaded diaphragm sensing, balanced plug pressure reducing valves are designed for use with clean air, nitrogen, carbon dioxide, oxygen, argon and other gases or liquids compatible with the construction materials and valve design.

This valve is specifically designed for the high purity gas systems found in the pharmaceutical, cosmetic, fine chemical and food & beverage processes.

MAIN FEATURES

- Compact design.
- Completely machined from 316L stainless steel bar stock, no castings or forgings are used.
- FDA / USP Class VI compliant seals.
- Non-rising adjustment knob.

STANDARD SURFACE FINISH

- Internal wetted parts: $\leq 0,51$ micron Ra – SF1.
- External: $\leq 0,76$ micron Ra – SF3.
- Other surface conditions see IS PV20.00 E – Technical information.
- Ultrasonic cleaning.

- OPTIONS:
- Self relieving.
 - Leakage line connection 1/8" (captured vent).
 - Gauge connection on body.
 - Different soft valves for liquids and gases.

- USE:
- Clean air, nitrogen, carbon dioxide, oxygen, argon and other gases or liquids compatible with the construction.

- AVAILABLE MODELS:
- P130K.

- SIZES:
- 1/2" to 3/4"; DN 08 to DN 20.

- REGULATING RANGES:
- 0,2 to 1,5 bar; 0,3 to 3 bar; 2 to 8 bar.

- CONNECTIONS:
- ASME BPE, DIN and ISO clamp ferrules or tube weld (ETO) ends.

- PACKAGING:
- Assembling and packaging in a clean room certified according to ISO 14644-1.
 - The product is end capped and sealed with recyclable thermo-shrinkable plastic film, to avoid contamination.

- INSTALLATION:
- Horizontal installation recommended.
 - See IMI – Installation and maintenance instructions.

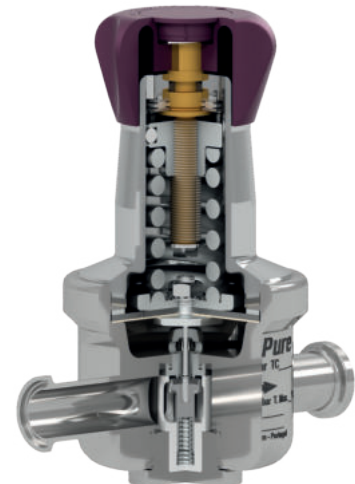

LIMITING CONDITIONS	
Valve model	P130K
Body design conditions	PN 16
Maximum upstream pressure	16 bar
Maximum downstream pressure	8 bar
Minimum downstream pressure	0,2 bar
Maximum design temperature *	150 °C

* Others on request.

CE MARKING – GROUP 2 (PED – European Directive)	
PN 16	Category
1/2" to 3/4" – DN 08 to 20	SEP

FLOW RATE COEFFICIENTS (m³/h)						
SIZE	ASME BPE		DIN		ISO	
	1/2" to 3/4"		DN 10 to DN 20		DN 08 to DN 15	
Kvs	0,7	1,3	0,7	1,3	0,7	1,3

DIMENSIONS (mm) ASME BPE											
SIZE	A	B	C	D	d1	d2	d3	E	F	H	WEIGHT (kg) *
1/2"	130	28	125	80	25	15,75	1/4"	65	25	9,4	2,4
3/4"	130	28	125	80	25	15,75	1/4"	66,5	25	15,75	2,4

* Valves with nylon adjustment knob weigh 0,3 kg less.

DIMENSIONS (mm) DIN											
SIZE	A	B	C	D	d1	d2	d3	E	F	H	WEIGHT (kg) *
DN 10	120	28	125	80	25	15,75	1/4"	65	34	10	2,4
DN 15	120	28	125	80	25	15,75	1/4"	66,5	34	16	2,4
DN 20	120	28	125	80	25	15,75	1/4"	66,5	34	20	2,6

* Valves with nylon adjustment knob weigh 0,3 kg less.

Remarks: Clamp ferrules according to DIN 32676-A; Tube weld (ETO) according to DIN 11866-A (DIN 11850-2).

DIMENSIONS (mm) ISO											
SIZE	A	B	C	D	d1	d2	d3	E	F	H	WEIGHT (kg) *
DN 08	120	28	125	80	25	15,75	1/4"	65	25	10,3	2,4
DN 10	120	28	125	80	25	15,75	1/4"	65	25	14	2,4
DN 15	120	28	125	80	25	15,75	1/4"	66,5	50,5	18,1	2,6

* Valves with nylon adjustment knob weigh 0,3 kg less.

Remarks: Clamp ferrules according to DIN 32676-B; Tube weld (ETO) according to DIN 11866-B (ISO 1127).

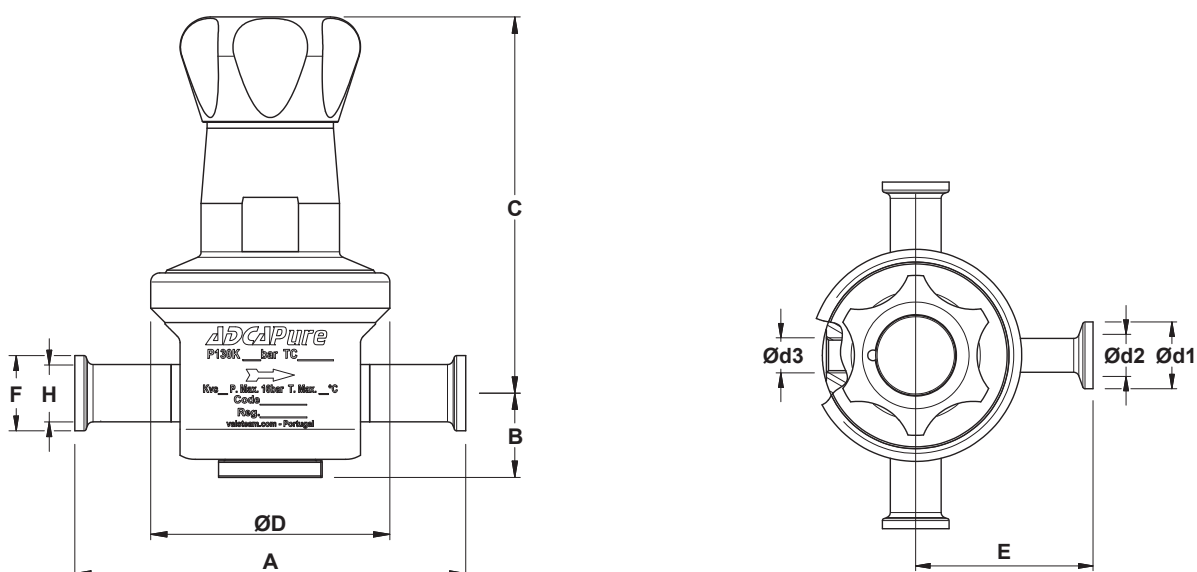

Optional pressure gauge connection.

MATERIALS

POS. N°	DESIGNATION	MATERIAL
1	Body	AISI 316L / 1.4404
2	Cover	AISI 316L / 1.4404
3	Seat cover	AISI 316L / 1.4404
4	* O-ring	EPDM
5	* Piston	AISI 316 / 1.4401
6	* Valve head	EPDM
8	* Valve spring	Spring steel
9	* Seat	AISI 316L / 1.4404
10	* O-ring	EPDM
11	* Guide	TFM 1600
12	* Stem	AISI 316L / 1.4404
13	* O-ring	EPDM
14	Pusher disc	AISI 316L / 1.4404
15	* Lower diaphragm	PTFE (Gylon)
16	* Upper diaphragm	EPDM
17	Washer	AISI 304 / 1.4301
18	Spring plate	AISI 316 / 1.4401
19	Nut	AISI 304 / 1.4301
20	Washer	AISI 304 / 1.4301
21	* Adjustment spring	AISI 302 / 1.4300
22	Spring plate	AISI 316 / 1.4401
23	Adjustment screw	Brass
24	Washer	Stainless steel A2-70
25	Bolt	Stainless steel A2-70
26	Adjustment knob	AISI 316L / 1.4404
		Nylon
27	O-ring	NBR
28	Bearing	Corrosion resistant steel
29	Ext. bowed shaft ring	Stainless steel
30	Cover nut	Plastic
31	Captured vent ring	AISI 316 / 1.4401
32	O-ring	EPDM
33	O-ring	NBR
34	Bolt	AISI 304 / 1.4301
35	O-ring	Viton
36	Compression fitting	AISI 304 / 1.4301

* Available spare parts ; ** If applicable.

Remarks: FDA / USP Class VI seals certificate on request.

All valves have a serial number. In case of non-standard valves, this number must be supplied if spare parts are ordered.

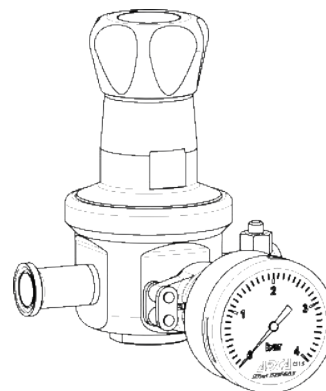
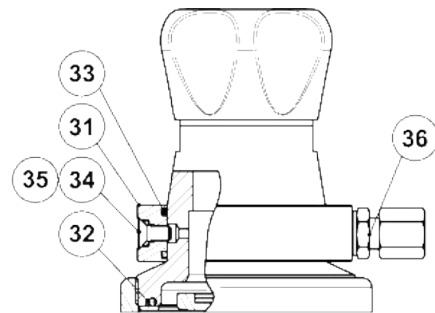
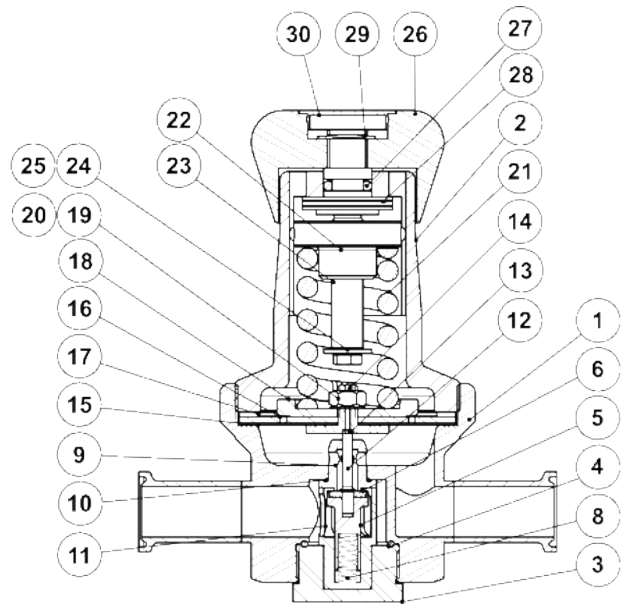

Optional pressure gauge connection.

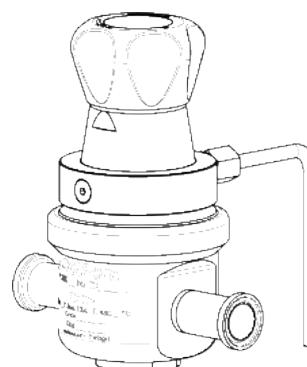

Optional 1/8" captured vent and/or leakage connection (compression fitting and tube not included).

ORDERING CODES P130K												
Valve model	P3K	1	2	T	M	X	I	X	X	X	DI	08
P130K – AISI 316L / 1.4404 diaphragm sensing pressure reducing valve	P3K											
Regulating range												
0,2 to 1,5 bar		1										
0,3 to 3 bar		2										
2 to 8 bar		3										
Flow rate coefficient												
Kvs 0,7		3										
Kvs 1,3		5										
Diaphragm												
PTFE (Gylon)				T								
EPDM (non-standard)				E								
Seat material												
Metal to metal (non-standard)					M							
EPDM					E							
PTFE					T							
FPM / Viton (FDA approval only)					V							
Relieving												
Non-relieving						X						
Relieving (only for non-dangerous gases)						R						
Relieving with captured vent						L						
Adjustment knob and top cap												
Stainless steel adjustment knob							I					
Nylon adjustment knob							P					
Top cap (adjustment screw with cover)							T					
Gauge port options												
Without gauge ports								X				
Tri-clamp gauge port on the left side (rel. to the flow direction) – downstream pressure								7				
Tri-clamp gauge port on the right side (rel. to the flow direction) – downstream pressure								6				
Tri-clamp gauge port on both sides – downstream pressure								5				
Threaded gauge port on the left side (rel. to the flow direction) – downstream pressure – ISO 7 Rp 1/4"								4				
Threaded gauge port on the right side (rel. to the flow direction) – downstream pressure – ISO 7 Rp 1/4"								3				
Threaded gauge port on both sides – downstream pressure – ISO 7 Rp 1/4"								2				
Threaded gauge port on the left side (rel. to the flow direction) – downstream pressure – 1/4" NPT								W				
Threaded gauge port on the right side (rel. to the flow direction) – downstream pressure – 1/4" NPT								Y				
Threaded gauge port on both sides – downstream pressure – 1/4" NPT								Z				
Surface finish a)												
Standard surface finish									X			
Mirror mechanical polished external surfaces (SF1)									P			
Electropolished internal wetted parts (SF5)									E			
Special features												
None											X	
Degreased for oxygen											O	
Pipe connection												
Clamp ferrule ASME BPE												D
Clamp ferrule DIN (DIN 32676-A)												F
Clamp ferrule ISO (DIN 32676-B)												E
Tube weld (ETO) according to ASME BPE												DI
Tube weld (ETO) according to DIN 11866-A (DIN 11850-2)												FI
Tube weld (ETO) according to DIN 11866-B (ISO 1127)												EI
Size												
DN 08												08
DN 10												10
1/2" or DN 15												15
3/4" or DN 20												20
Special valves / Extras												
Full description or additional codes have to be added in case of non-standard combination												E

a) Consult IS PV20.00 for further details and other surface finish options.