

DIRECT STEAM INJECTION HUMIDIFIERS DSH Series

DESCRIPTION

The DSH direct steam injector humidifiers assure highly efficient steam release into the air stream. Each humidifier is designed for your specific capacity, steam pressure and duct width requirements. Single and multiple injection tube units are available to meet the most demanding applications.

High quality control valves and actuators assure accurate response and control of the steam flow.

OPERATION

Single tube and multiple tube humidifiers operate with the same basic design. The steam enters the humidifier separator through the strainer. Separation of the steam and condensate is achieved by the action of our S25 centrifugal separator (special version). Inside the separator, the combination of steam and condensate is directed into the drain baffle, where condensate is drained through the bottom of the separator and removed from the system by a float and thermostatic steam trap.

The steam, free of condensate, then flows out of the separator and into the injection tube. The steam connection to the outer jacket is recommended to be directly from the steam system, in case of multiple tube design, or from the top of the separator, in case of single tube design.

MAIN FEATURES

Complete stainless steel injection tube and separator construction.

Quiet operation.

OPTIONS: Single or multiple tube systems.

ACCESSORIES: Steam traps and strainer.

USE: Saturated steam.

AVAILABLE MODELS: DSH15-10; DSH20-20; DSH25-20; DSH 40-30.

SIZES: 1/2" to 1 1/2".

CONNECTIONS: Female screwed ISO 7/1 Rp (BS21). Flanged connections upon request.

INSTALLATION: Horizontal installation in horizontal or vertical air ducts. See IMI – Installation and maintenance instructions.

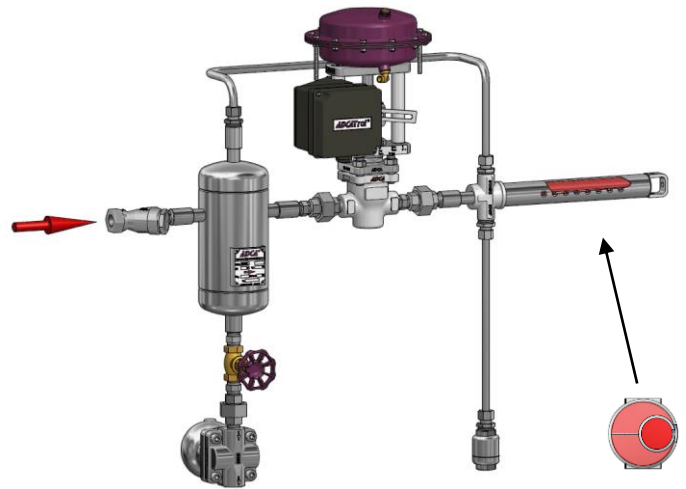

Single tube design

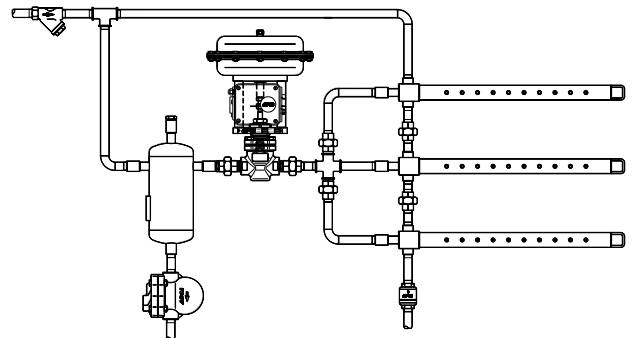

Multiple tube design

LIMITING CONDITIONS	
Separator body design conditions	PN6
PS – Maximum allowable pressure	4 bar
TS – Maximum allowable pressure	152 °C

Minimum operating temperature: - 10 °C;

Design code: AD – Merkblatt;

Other conditions and CE marking on request.

When using multiple tube pipe design, the injection tubes are piped and trapped separately, to ensure that the additional resistance created by extra piping does not reduce the steam supply to the humidifier and also to provide extra trap capacity, to handle the additional condensate created within the multiple injection tube steam jackets.

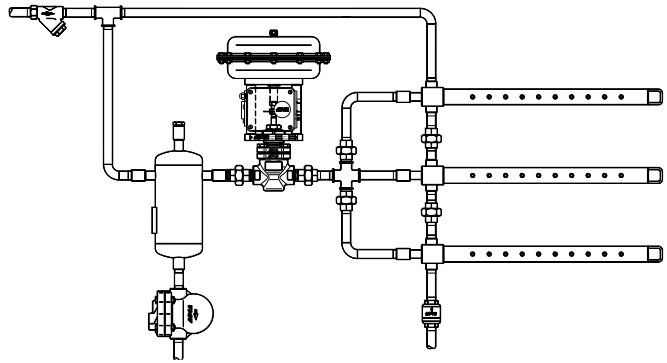

MULTIPLE TUBE HUMIDIFIER	
Recommended number of tubes	
Duct height (mm)	N° of tubes
Up to 900	2
920 – 1200	3
1220 – 1800	4
1820 – 2400	5
above 2400	6

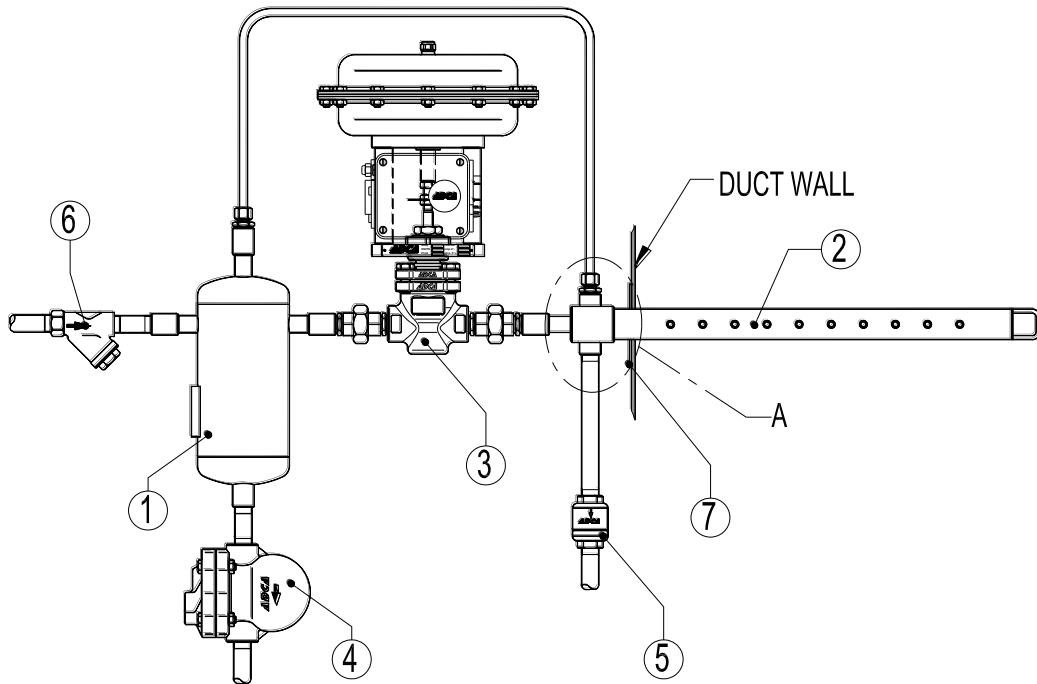

MATERIALS		
POS. N°	DESIGNATION	MATERIAL
1	Steam separator	Stainless steel
2	Injection tube	Stainless steel
3	* Adcatrol valve	On request
4	* ADCA float steam trap	Stainless steel / Cast iron
5	*ADCA TSS22 steam trap	Stainless steel
6	ADCA IS16	Cast iron
7	Fixing plates	Stainless steel

* Available spare parts.

DIMENSIONS (mm)																
MODEL	SIZE	A	B	C	D	E	F	G	H	I	J	L	T	U	V	R
DSH15-10	1/2"	230	114	199	145	1/2"	*	38	76	**	1/2"	M10	100	50	228	19
DSH20-20	3/4"	230	114	199	150	1/2"		51	89		3/4"	M10	110	55	100	25,4
DSH25-20	1"	266	140	270	160	3/4"		51	89		3/4"	M10	110	55	100	25,4
DSH40-30	1 1/2"	304	168	380	200	3/4"		76	121		1 1/4"	M10	130	75	120	38,3

* Depends on the valve selected;

** Special tube lengths available on request, consult factory for more details.

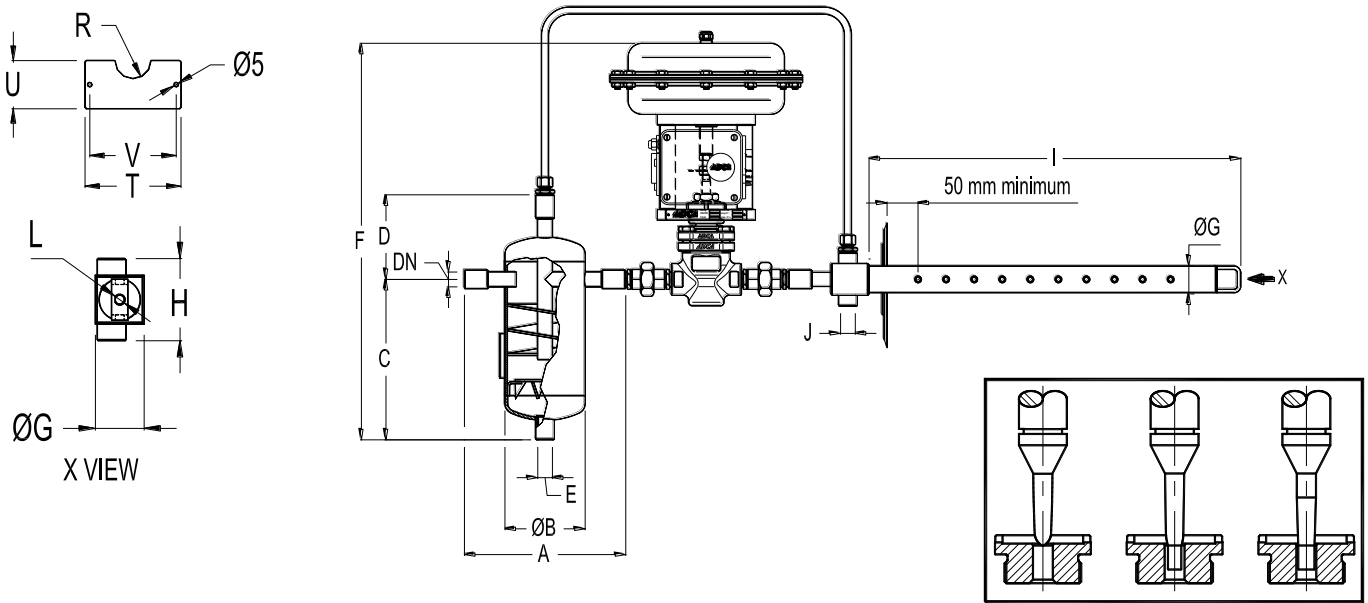
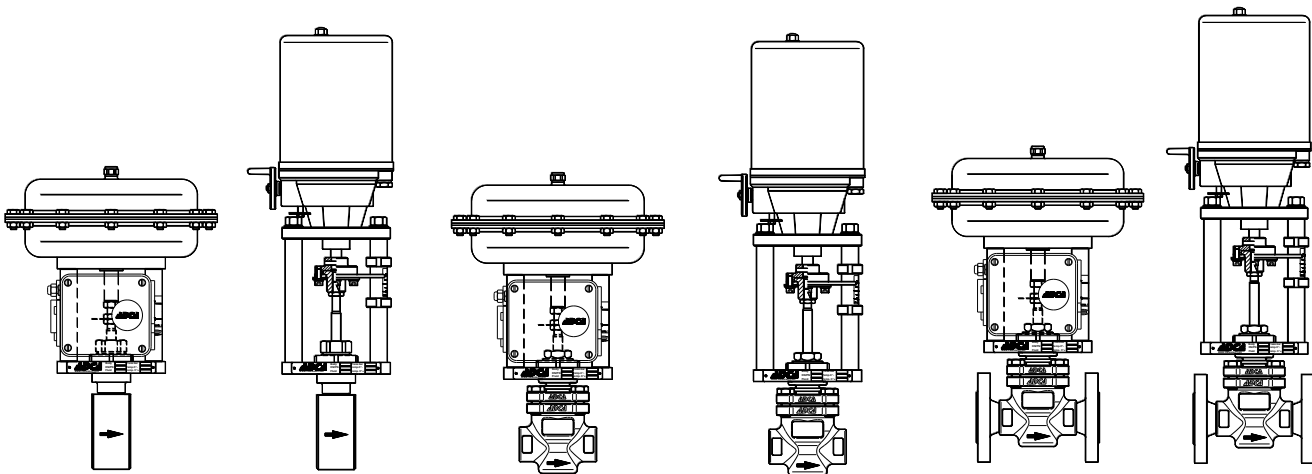

Fig.1

VALVES AND ACTUATORS

The ADCATrol line offers a large range of control valve options (Fig.2) for electric or pneumatic fine control, including low flow designs (Fig.1). Please ask for specific documentation according to your selection.



PWV / EWV Wafer type

PV25 / EV25 Threaded

PV25 / EV25 Flanged

Fig.2

SELECTION AND CAPACITY TABLES

TABLE 1 – INJECTION TUBE HUMIDIFIER, SEPARATOR / VALVE STEAM CAPACITY (kg/h)

MODEL	VALVE (Kv – SIZE)	STEAM PRESSURE TO HUMIDIFIER SUPPLY CONNECTION (barg)																						
		0,14	0,20	0,27	0,35	0,40	0,48	0,55	0,60	0,68	0,75	0,80	0,90	0,95	1,00	1,35	1,70	2,00	2,40	2,70	3,00	3,50	3,75	4,00
DSH15	0,09 – 1/2"	0,75	0,85	1	1,2	1,3	1,4	1,5	1,6	1,65	1,75	1,8	1,9	1,95	2	2,3	2,6	2,85	3	3,3	3,5	3,65	3,85	4
	0,19 – 1/2"	1,59	1,9	2,37	2,54	2,81	2,99	3,22	3,45	3,63	3,8	3,9	4	4,4	4,5	4,98	5,9	6,4	6,8	7,3	7,7	8,2	8,6	9
	0,35 – 1/2"	2,9	3,5	4,2	4,5	5	5,5	5,9	6,4	6,8	6,8	7,3	7,3	7,7	8,2	9	10,5	11,4	12,3	13,2	14	15	15,5	16,5
	0,65 – 1/2"	5,5	6,5	7,7	8,6	9,5	10,5	11	11,8	12,5	12,7	13,6	14	14,5	15	17,3	19,5	21,3	22,7	24,5	25,8	27,2	28,6	30
	0,80 – 1/2"	6,8	8,2	9,5	10,9	12,3	13,2	14	15	15,4	16,3	17,3	17,7	18,2	19	21,8	24,5	26,7	29	30,8	32,7	34,5	36,3	38
	1,20 – 1/2"	9,5	10,9	13,2	15	16,3	17,7	19	20	21,3	22,3	23,2	24	25	25,8	30	33,5	36,3	39,5	42,2	45	47,2	49,5	51,7
	1,50 – 1/2"	12,7	15	18,2	20	22,3	23,5	25,4	27,2	28,6	30	31,3	32,6	33,5	34,5	40	44,9	48,5	52,6	56,3	59,8	63	66,3	69,5
	1,90 – 1/2"	15,9	18,6	22,7	25	27,7	30	32,2	34	35,8	37,2	39	40,8	42	43	50,3	55,8	60,8	66,3	70,8	74,8	78,9	83	87
	2,80 – 1/2"	23,5	27,7	33	37,2	40,8	43,5	47,2	49,9	52,6	54,8	57,6	59,8	62,2	63,5	74	82	89,8	97	103,8	110,7	116,6	122,5	128
	3,80 – 1/2"	31,7	37,6	44,5	50	54,8	59	64	67,5	71,2	74	78	80,8	83,9	86	100	111	121	132	140,6	148,8	156,5	164,7	172,8
DSH20	4,75 – 3/4"	38,5	47	55,8	62,5	68	73	79,8	84,4	88,9	92,5	96,6	101	105	107	125	138	151	163	174,6	185	195	204	214
	5,3 – 3/4"	43,5	53	62,5	70,3	76,6	82,5	89,8	95	99,8	104	109	113	118	120	141	156	169	183	196,9	208	220	230,5	240
	6,5 – 3/4"	52,6	64,5	75,3	84,4	92,5	99,8	108	115	120	126	131	137	142	145	170	187	204	221	238	251,8	265,4	278,5	290,4
DSH25	7,00 – 1"	55,8	70,3	81,7	92,5	101	109	118	125	132	138	142	149	155	158	185	201	221	240	258,5	273,5	288	303	319
	8,60 – 1"	68	85,8	99,8	113	123	133	144	152	161	168	172	182	188	192	226	245	267	293	315	331,4	349	367,5	385,5
	10,30 – 1"	81,7	104	120	134	148	159	172	182	192	200	207	211	223	230	270	294	324	351	375	397	–	–	–
DSH40	17,20 – 32	136	170	199	224	245	264	286	302	318	334	340	350	369	378	449	481	535	580	624	662	–	–	–
	24,00 – 40	190	232	278	311	343	368	396	420	444	465	473	488	512	528	627	673	743	806	867	927	–	–	–

* Depends on the valve selected;

** Special tube lengths available on request, consult factory for more details.

TABLE 2 – INJECTION TUBE HUMIDIFIER, SEPARATOR / VALVE STEAM CAPACITY (kg/h)

TUBE MODEL	STEAM PRESSURE TO HUMIDIFIER SUPPLY CONNECTION (barg)																						
	0,14	0,20	0,27	0,35	0,40	0,48	0,55	0,60	0,68	0,75	0,80	0,90	0,95	1,00	1,35	1,70	2,00	2,40	2,70	3,00	3,50	3,75	4,00
10	43	52	61	69	76	82	88	95	102	108	114	120	125	131	137	143	149	155	160	166	172	178	184
20	84	100	121	140	154	168	182	197	210	222	235	248	260	273	285	298	311	324	337	349	362	375	387
30	151	189	222	260	300	309	333	357	381	405	429	453	477	501	525	549	573	597	621	645	670	693	718

** Special tube lengths available on request, consult factory for more details.

Model Nomenclature:

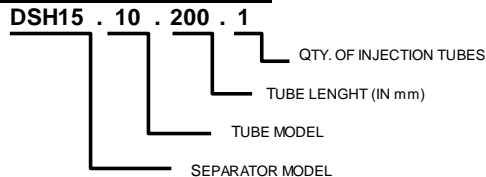

Example (simple tube):

Total humidification load of 36 kg/h at 1,35 bar.
Number of injection tubes required: 1
Duct width: 200 mm.
From Table 1 we see that a Model DSH 15 separator is required with a valve with Kv = 1,5. From Table 2 you will see that a Model 10 injection tube, at 1,35 bar, can emit the required tube humidification load.
The correct model code would be:
DSH15.10.200.1
Control valve code, if supplied, should be according to the selected model.

Example (multiple tube):

Total humidification load of 180 kg/h at 1,7 bar.
Number of injection tubes required: 2
Injection tube humidification capacity: 90 kg/h
Duct width: 1200 mm
From Table 1 you will see that a Model DSH20 separator is required with valve Kv=6,5.
From table 2 you will see that a Model 10 injection tube, at 1,7 bar can emit the required tube humidification load.
The correct model code would be:
DSH20.10.1200.2
Control valve code, if supplied, should be according to the selected model.