

STEAM - WATER MIXERS MX20

DESCRIPTION

The steam/water Adcamix MX20 mixers provide a cheap and instantaneous source of low pressure hot water, by using existing steam and cold water supplies.

The mixer incorporates a safety device, to ensure that live steam cannot be accidentally ejected even if, for some reason, the cold water supply fails.

The temperature of water at the outlet of the Adcamix is easily controlled by using water and steam valves fitted to the inlets.

MAIN FEATURES

- Instant source of low pressure hot water.
- Safety device against accidental steam ejection.
- Non return valves included.
- Complete stainless steel construction.
- Quiet operation.

OPTIONS: Alternative steam valve if live steam is required, e.g. for sterilisation.

ACCESSORIES: Stainless steel pedestal.
Adjustable spray gun.
Steam/water inlet valves.
Hot water/steam hose.
Stainless steel suspension for hose.

USE: Saturated steam and cold water.

AVAILABLE MODELS: MX20.

SIZES: 3/4" x 3/4".

CONNECTIONS: Female threaded ISO 7/1 Rp.

INSTALLATION: Vertical wall installation.
See IMI – Installation and maintenance instructions.



FLOW RATE CAPACITY – HOT WATER FLOW (L/h)							
STEAM PRESSURE (bar)	HOT WATER OUTLET TEMPERATURE						
	40 °C	50 °C	60 °C	70 °C	80 °C	90 °C	95 °C
2,5	1900	1400	1150	900	700	650	600
3	2250	1600	1230	1030	900	800	700
4	2700	2000	1550	1250	1000	850	800
5	3250	2300	1800	1500	1250	900	850
6	3900	2900	2250	1800	1500	1200	1100
7	4200	3100	2400	1950	1600	1300	1200
8	4800	3500	2700	2100	1800	1550	1280
9	5200	3900	3000	2450	2000	1700	1600
10	5900	4100	3250	2700	2250	1900	1750

APPLICATION LIMITS	
Minimum steam pressure	2,5 bar
Maximum steam pressure	10 bar

Remarks:
Steam pressure must be equal to or lower than 3 times the water pressure;
Water pressure cannot be higher than steam pressure.

DIMENSIONS (mm)						
SIZE	A	B	C	D	E	WEIGHT (kg)
3/4"	134	220	116	57,5	337	7

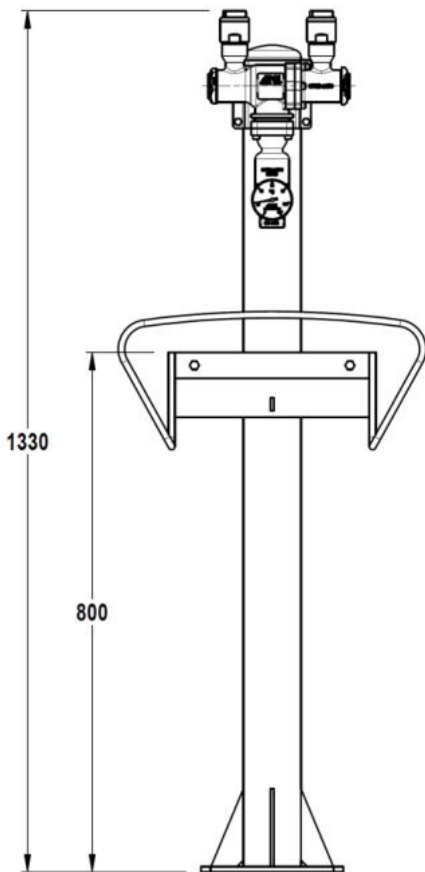
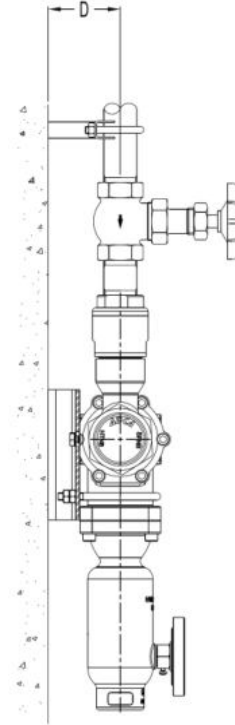
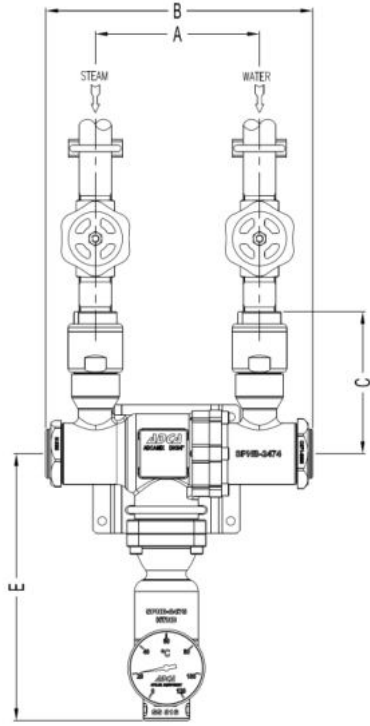

Stainless steel pedestal

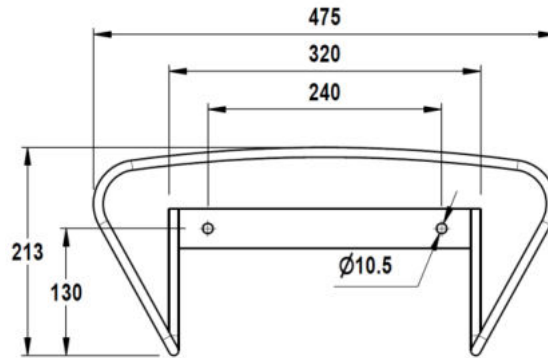

Stainless steel support for hose

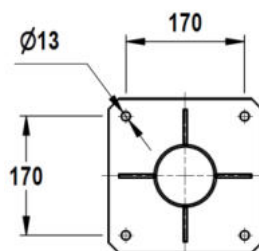
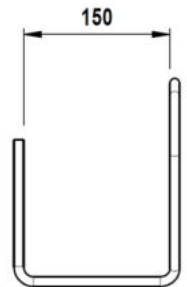

Pedestal base

MATERIALS

POS. N°	DESIGNATION	MATERIAL
1	Steam body	CF8M / 1.4408
2	Water body	CF8M / 1.4408
3	* Gasket	NBR
4	Bolts	A2-70
5	* Steam valve	St. steel / Graphite
6	* Valve spring	AISI 302 / 1.4300
7	Steam cover	AISI 316 / 1.4401
8	* Gasket	PTFE
9	* Piston	AISI 316 / 1.4401
10	Water cover	AISI 316 / 1.4401
10A	Steam valve	AISI 316 / 1.4401
10B	* Packing	PTFE
11	Steam nozzle	AISI 316 / 1.4401
12	Mixing chamber	CF8M / 1.4408
13	* Gasket	Viton
14	Support	AISI 304 / 1.4301
18	* Check valve	AISI 316 / 1.4401
19	* Gasket	PTFE

* Available spare parts.

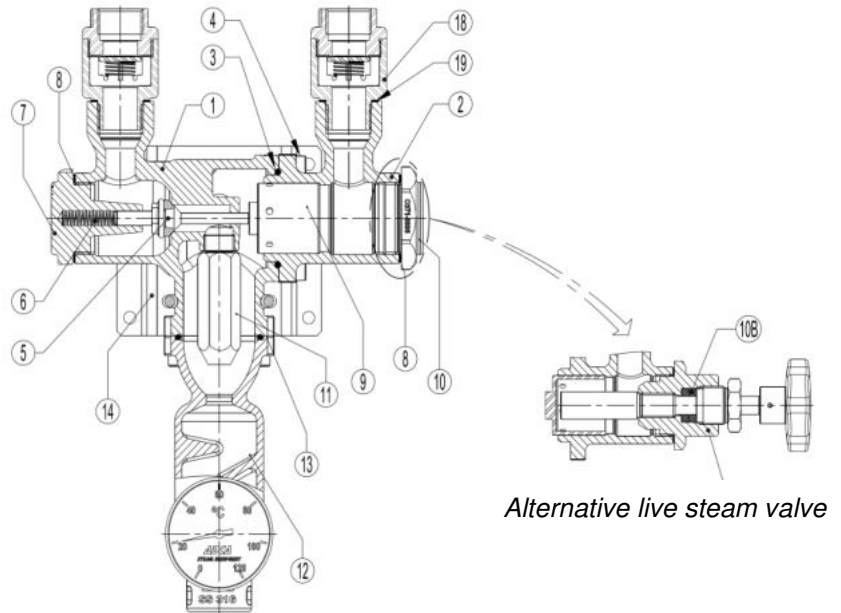

Alternative live steam valve

HOSE TECHNICAL SPECIFICATIONS

Tube materials	NBR rubber, clear colour, food quality, odourless, tasteless, smooth, mirror-like; Complies with FDA standards, BfR recommendations and M.D. 21/03/73 and following amendments.
Cover materials	NBR rubber, blue colour, abrasion, ozone and weather resistant, smooth, cloth finish.
Reinforcement materials	Heat resistant synthetic textile plies.
Temperature range	From -20 °C to 95 °C; Up to 164 °C for saturated steam cleaning operations (short peaks) – limited to a working pressure of 6 bar. Sterilisation up to 130 °C for a maximum time of 30 minutes.
Inner diameter	19 mm.
Outer diameter	31 mm.
Wall thickness	6 mm.
Burst pressure	60 bar.
Approx. weight	0,58 kg/m.