

## ATMOSPHERIC SEMI – DEAERATORS ADG

### DESCRIPTION

The ADCATherm atmospheric semi-deaerators are designed to heat boiler feed water and to reduce oxygen and carbon dioxide (oxygen values in the feed water of less than 1,6 mg/L can be achieved). Remaining oxygen can be completely removed using oxygen scavenging chemicals.

Basically, the complete system consists of a storage vessel, a deaeration head section and a vent.

### OPERATION

Hot return condensate is injected in the bottom of the storage vessel using an adequate sparger pipe and softened make-up water is introduced in the deaerator head to be heated by a contact cascade flash steam heating system (counter-current flow) coming from the vessel. A part of the dissolved gases is liberated from the water at this point, and then to the atmosphere, through the flash steam vent line.

The semi-deaerated water then falls to the storage vessel below, where a steam injection system will provide an additional deaeration. The complete unit is supplied, including all the necessary instrumentation for temperature and level control, to be described in our offer, depending on the operation conditions (see Table 1).

### MAIN FEATURES

- Prevents energy wasting.
- Easy to install.
- Can be installed on new or existing systems.
- Reduces the flow of flash steam from the vessel venting pipe.
- Long life expectancy.

- OPTIONS:**
- Complete stainless steel construction.
  - Complete system including all the necessary equipments.
  - Vent condenser for energy recovery.

- USE:** Steam boiler feed water.

### AVAILABLE

- MODELS:** ADG – Deaerator head.

- CONNECTIONS:** Flanged EN 1092-1 or ASME.  
ISO or NPT threaded sockets.  
Different connections on request.

- CONSTRUCTION:** Carbon steel with internal stainless steel components.

- INSTALLATION:** Deaerator head – vertical installation.  
Storage vessel – cylindrical horizontal design.  
Final dimensions and connections according to the drawing supplied after order confirmation.



LIMITING CONDITIONS	
PS – Maximum allowable pressure	0,5 bar
TS – Maximum allowable temperature	120 °C

Minimum operating temperature: -10 °C;

Design code: AD-Merkblatt.

Remark: other conditions and CE marking on request.

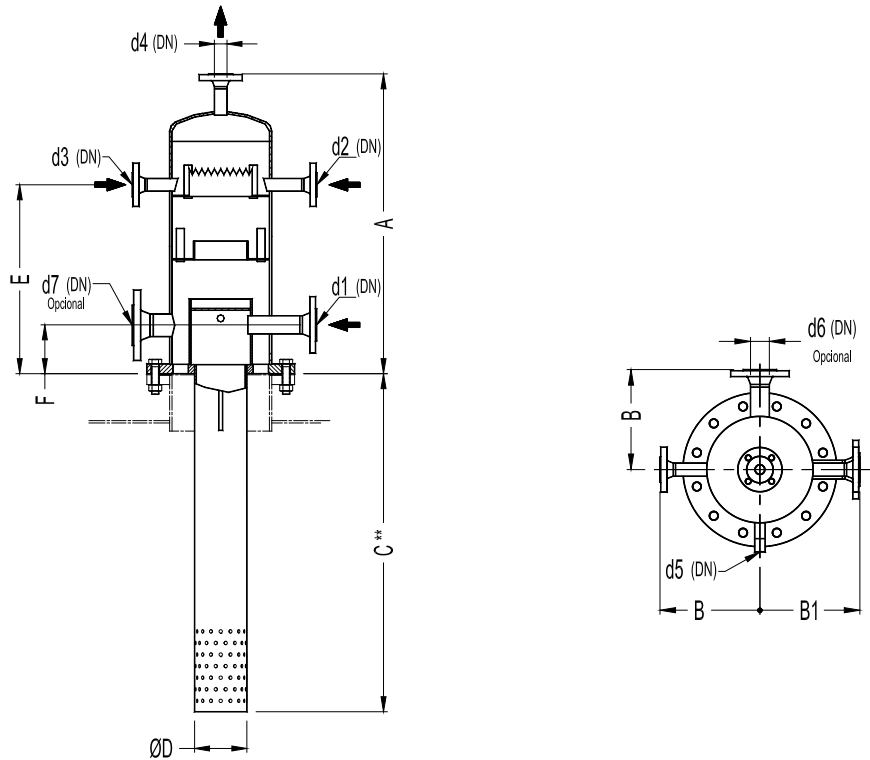

**DIMENSIONS (mm)**

MODEL	A (mm)	B (mm)	C (mm)	D (mm)	E (mm)	F (mm)	d1 (DN)	d2 (DN)	d3 (DN)	d4 (DN)	d5 (DN)	d6 * (DN)	d7 * (DN)	WGT. (kg)
ADG150	610	184	**	80	400	125	50	25	25	40	1/2"	50	50	***
ADG200	670	210	**	120	425	160	80	32	25	50	1/2"	65	65	***
ADG250	860	237	**	140	580	190	100	50	25	65	1/2"	80	80	***
ADG300	900	265	**	170	610	190	100/150	65	40	80	1/2"	100	100	***
ADG400	780	510	**	220	490	180	150	80	40	100	1/2"	125	125	***

d1 – hot condensate inlet; d2 – cold make-up water; d3 – recirculating pump connection; d4 – vent; d5 – pressure gauge connection; d6 – cold condensate return; d7 – flash steam;

\* Optional; \*\* Dimensions on request; \*\*\* Weight to be confirmed.

**SELECTION TABLE**

MAX. STEAM GENERATION (kg/h)	5000	10000	20000	30000	50000
MODEL	ADG150	ADG200	ADG250	ADG300	ADG400

**THERMAL DEAERATOR DATA INQUIRY**

Make-up water pressure		bar
Make-up water temperature		°C
Make-up water flow rate		kg/h
Condensate return pressure		bar
Condensate temperature		°C
Condensate flow rate		kg/h
Saturated heating steam pressure		bar
Feed water tank required capacity		m <sup>3</sup>
Max. deaerated water flow required		kg/h

Table 1

**TYPICAL INSTALLATION**

**Semi - deaerator system with cold make-up water**

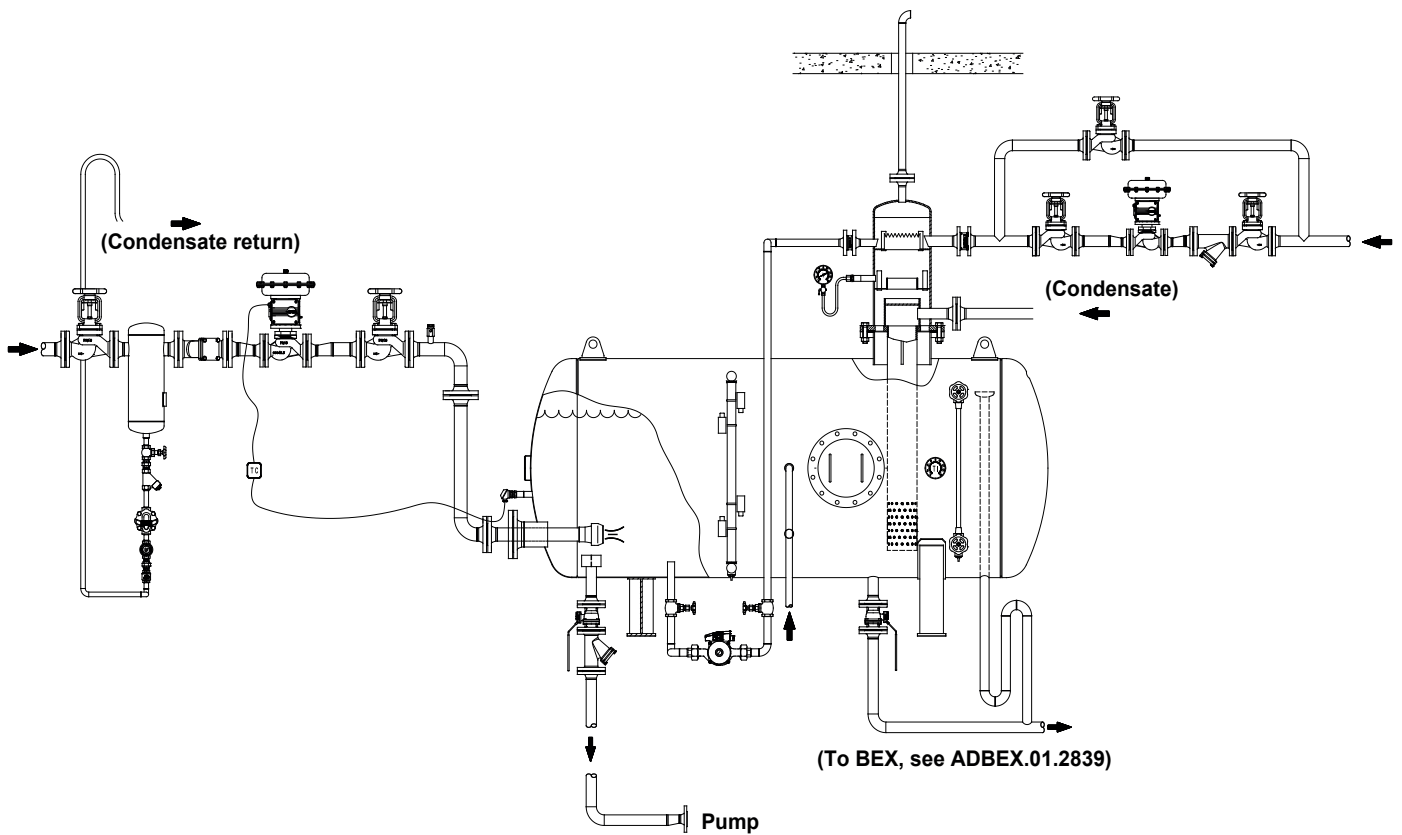

Atmospheric deaerator provides an economic system to preheat boiler feed water and remove dissolved gases.

The steam injector can be supplied with flanges and pipe, ready to adapt to existing vessels.

The feed water is re-circulated using a low power re-circulating pump which will improve thermal efficiency by reducing the temperature stratification.

For more detailed information please see assembly drawing ADADGV.01.2844.

**TYPICAL INSTALLATION**

**Semi - deaerator system with vent condenser**

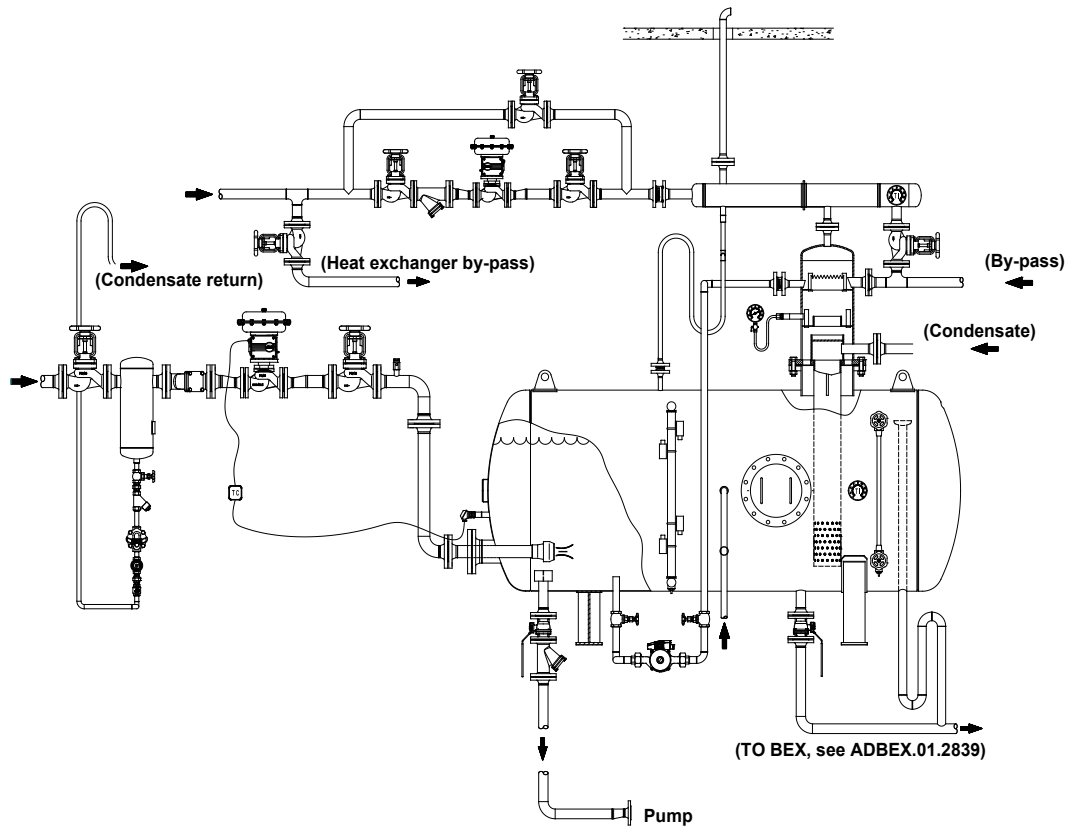

Atmospheric deaerator including ADCATherm STS series complete stainless steel heat exchanger. Make-up water crossing the heat exchanger will condense the flash steam, preventing energy waste and providing better performance for the whole system.

The steam injector can be supplied with flanges and pipe, ready to adapt to existing vessels.

The feed water is re-circulated using a low power re-circulating pump which will improve thermal efficiency by reducing the temperature stratification.

For more detailed information please see assembly drawing ADADGV.02.2845.