

HUMIDITY SEPARATORS S25/S PN16 – PN40

DESCRIPTION

The S25 series centrifugal separators remove moisture from steam and compressed air pipelines. Steam and compressed air pass through the separator and, as a result of centrifugal forces, impacts and swirling effects, the particles with a heavier specific gravity, such as water and oil droplets, moisture in suspension, dirt and scale are separated from the fluid.

The condensate collected at the bottom of the separator must be automatically drained by a suitable steam or compressed air trap.

MAIN FEATURES

Several possibilities of installation.
No moving parts.

OPTIONS: Zinc plated (compressed air).
Condensate flanged connection.

USE: Steam, compressed air and other gases (Group 2).

AVAILABLE MODELS: S25/S – Carbon steel body.
S25/SZ – Hot-dip galvanization.

SIZES: DN 15 to DN 300.

CONNECTIONS: Flanged EN1092-1 PN16/40.
Flanged ANSI B16.5 Class 150 lb or 300 lb.
Female threaded ISO 7 Rp or NPT on request.
Standard PN16 DN65 flanges are supplied with 4 holes. 8 holes, according to EN 1092, on request.

INSTALLATION: Always with the condensate discharge pointing downwards. See IMI – Installation and maintenance instructions.

HOW TO SELECT: Generally, in an existing plant, it is advisable to fit a separator with the same size as the pipeline. Pressure drop is normally negligible. For approximate pressure drop calculation, consult factory.



CE MARKING – GROUP 2 (PED – European Directive)

Rating	Size	Category	Rating	Size	Category
PN16	DN 15 to DN 25	SEP	PN40	DN 15 to DN 32	1 (CE marked)
	DN 32 to DN 50	1 (CE marked)		DN 40 to DN 80	2 (CE marked)
	DN 65 to DN 125	2 (CE marked)		DN 100 to DN 150	3 (CE marked)
	DN 150 to DN 200	3 (CE marked)		DN 200 to DN 300	4 (CE marked)
	DN 250 to DN 300	4 (CE marked)		–	–

LIMITING CONDITIONS **

Rating	Pressure (bar)	Temperature (°C)	Rating	Pressure (bar)	Temperature (°C)	Rating	Pressure (bar)	Temperature (°C)
PN16	16	50	ANSI 150 lb	16	50	PN40 / ANSI 300 lb	40	50
	14	100		14	100		37	100
	13 *	195		13 *	195		32 *	239
	12	250		–	–		27	300

* PMO – Maximum operating pressure for saturated steam; ** Rating according to EN 1092-1:2018;

Minimum operating temperature: -10 °C;

Design code: AD-Merkblatt.

MATERIALS

DESIGNATION	MATERIAL
Body	EN 10216-2 / P235GH / 1.0325
Heads	EN 10028-2 / P265GH / 1.0425
Inlet / Outlet pipes	EN 10216-2 / P235GH / 1.0325
EN flanges	EN 10222-2 / P250GH / 1.0460
ANSI flanges	ASTM A105 / 1.0432
Sockets	ASTM A105 / 1.0432
Internals	EN 10025-2 / S235JR / 1.0038

EN 10204 3.1 certificate available if requested with the order.

FLANGE CONNECTIONS

Rating	Size	EN Standard	ANSI Standard
PN16	* DN 15 to DN 50	EN 1092-1 PN40	ANSI B16.5 Cl. 150 lb
PN16	DN 65 to DN 300	EN 1092-1 PN16	ANSI B16.5 Cl. 150 lb
PN40	DN 15 to DN 300	EN 1092-1 PN40	ANSI B16.5 Cl. 300 lb

* Flanges EN 1092-1 PN16 and PN40, from DN 15 to DN 50, have the same number and size of holes.

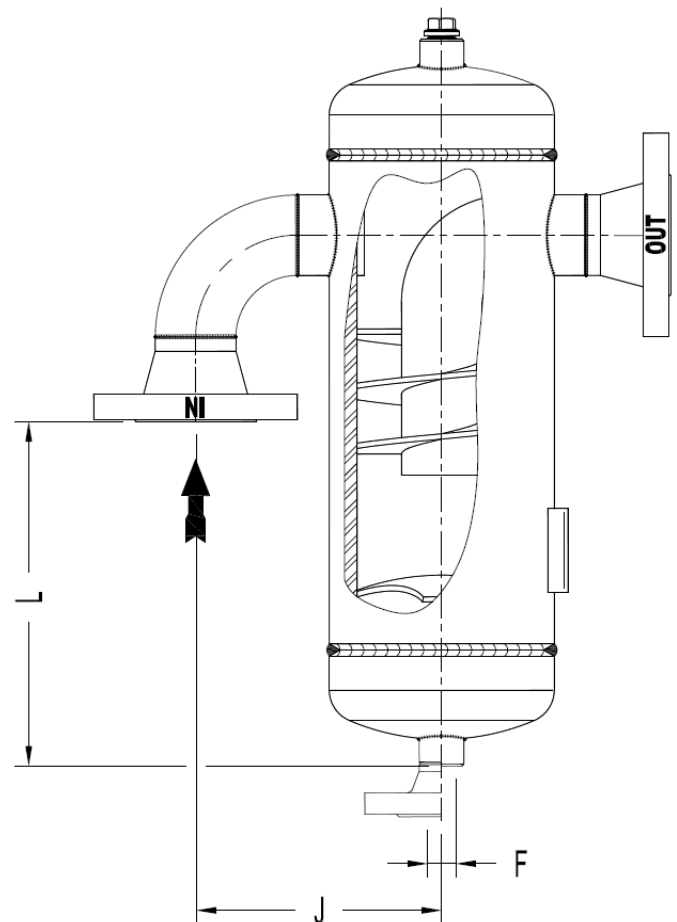
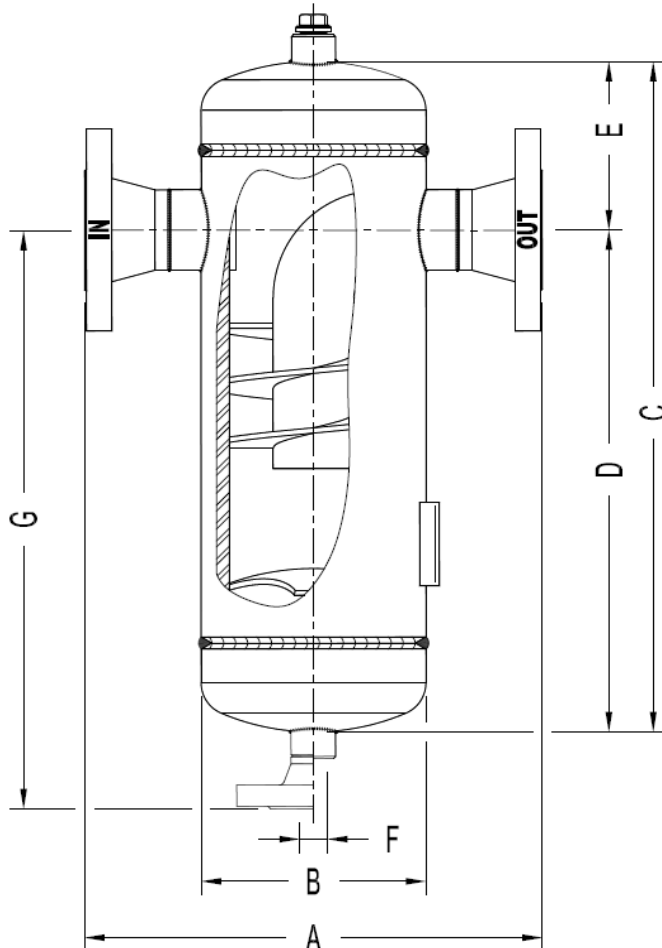

EVH - Elbow vertical inlet / horizontal outlet

APPROXIMATE DIMENSIONS (mm) *

SIZE DN	A PN16	A 150 lb	B	C	D	E	J	L PN16	L 150 lb	F **	G PN16	G 150 lb	VOL. (L)	WGT. (kg)
15	230	250	114	260	185	75	115	144	135	1/2"	245	255	2	5,4
20	230	255	114	260	185	75	115	136	123	1/2"	245	255	2,5	5,8
25	230	262	114	300	200	100	135	142	126	1/2"	260	270	3	6,8
32	260	290	140	395	285	110	155	194	200	1/2"	345	355	5	11,4
40	260	294	140	435	325	110	165	243	226	1/2"	385	395	5,7	12,6
50	310	341	168	505	385	120	190	281	265	1/2"	445	455	10,5	18,4
65 ***	380	430	219	550	410	140	240	275	250	3/4"	470	483	18,5	29,8
80	400	440	219	610	462	148	260	306	286	3/4"	522	535	25	33,6
100	470	520	273	715	528	187	330	326	302	3/4"	588	601	35,4	49,7
125	535	605	324	845	630	215	403	380	346	1"	688	704	50	76
150	565	633	356	960	690	270	457	428	394	1"	758	774	75	104
200	605	685	406	1170	880	290	545	485	446	1"	948	965	140	168,5
250	720	784	508	1540	1140	400	671	714	682	1 1/2"	1210	1227	280	318
300	860	933	610	1700	1172	528	800	662	626	1 1/2"	1262	1279	452	463

SIZE DN	A PN40	A 300 lb	B	C	D	E	J	L PN40	L 300 lb	F **	G PN40	G 300 lb	VOL. (L)	WGT. (kg)
15	230	259	114	275	190	85	115	144	130	1/2"	250	264	2	6,6
20	230	264	114	275	190	85	115	136	119	1/2"	250	264	2,5	7,4
25	230	274	114	300	200	100	135	142	120	1/2"	260	274	3	8,5
32	260	303	140	395	285	110	155	194	215	1/2"	345	360	5	13
40	260	307	140	435	325	110	165	243	220	1/2"	385	399	5,7	16
50	310	354	168	505	375	130	190	281	259	1/2"	435	450	10,5	24
65	394	442	219	550	395	155	240	268	244	3/4"	455	472	18,5	39
80	410	459	219	610	450	160	260	298	277	3/4"	510	527	25	44
100	490	530	273	715	510	205	330	313	293	3/4"	570	587	35,4	75
125	561	622	324	845	605	240	403	367	337	1"	668	690	50	114
150	605	652	356	960	690	270	457	408	385	1"	754	776	75	131
200	650	700	406	1170	830	340	545	459	436	1"	898	920	140	264
250	810	815	508	1540	1140	400	671	679	666	1 1/2"	1235	1259	280	454
300	914	964	610	1700	1172	528	800	625	597	1 1/2"	1262	1286	452	514

* For certified values, consult factory. Volume and weight refer to EN flanged versions. Other versions may have slightly different values.

** As standard, in separators manufactured with EN 1092-1 flanges, the drain connection is female threaded ISO 7 Rp. In models with ANSI B 16.5 flanges, this connection is female threaded NPT. Alternatively, EN 1092-1 or ANSI B 16.5 flanged drain connections can be supplied (ANSI on the same class as main connections).

*** Standard PN16 DN65 flanges are supplied with 4 holes. 8 holes, according to EN 1092, on request.

Remarks: The top of the separator is supplied with a threaded connection, which size does not exceed the size of the drain connection. This connection is always supplied with a threaded socket. It can be used for air venting or balance pipe connection.