

STS Series SHELL AND TUBE HEAT EXCHANGERS (Steam to water – Vertical installation)

DESCRIPTION

The ADCA STS series steam to water shell and tube heat exchangers are shorter and lighter than the alternative shell and tube exchangers manufactured with smooth pipes. The use of extruded low fin tube has the advantage that it can improve the external surface and thermal performance.

MAIN FEATURES

Corrosion-resistant stainless steel low finned tube bundle and shell construction.

Straight tubes for easy cleaning.

Expansion bellow in the shell, avoiding excessive tube stresses caused by thermal expansion and contraction.

OPTIONS: Horizontal installation.

USE: Steam, water, hot condensate and other fluids compatible with the construction.

AVAILABLE MODELS: STSV – Vertical installation.
STSH – Horizontal installation (optional).

INSTALLATION: Vertical or horizontal (different condensate heads execution).

ORDER

REQUIREMENTS: Steam pressure and temperature.
Inlet and outlet water temperature.
Water mass flow or heat exchanged.

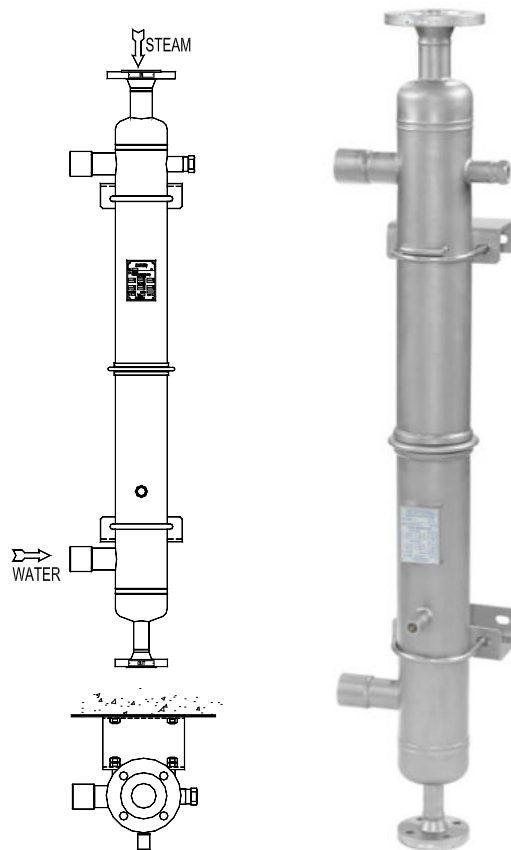

CE MARKING – GROUP 2 (PED – European Directive)	
DESIGNATION	MATERIAL
Tube bundle	AISI 316L / 1.4404
Tube sheet	AISI 316 / 1.4401
Heads and shell	AISI 316 / 1.4401; AISI 316L / 1.4404
Inlet / outlet pipes	AISI 316 / 1.4401
EN flanges	AISI 316 / 1.4401
ANSI flanges	AISI 316 / 1.4401
Sockets	AISI 316 / 1.4401
Supports	AISI 304 / 1.4301

EN 10204 3.1 certificate available, if requested with the order.
AISI 316L / 1.4404 on request.

CE MARKING – GROUP 2 (PED – European Directive)		
PN16	Category Tube side	Category Shell side
STSV 3.075 to 8.150	1 (CE marked)	SEP

BODY LIMITING CONDITIONS *					
SHELL	ALLOW. PRESS.	RELATED TEMP.	TUBE		
			ALLOW. PRESS.	RELATED TEMP.	
PN16	16 bar	50 °C	ANSI 150 lb	16 bar	50 °C
	15 bar	100 °C		15 bar	100 °C
	12,7 bar	200 °C		12,6 bar	200 °C
	12 bar	250 °C		–	250 °C

Min. operating temp.: -10 °C; Design code: AD-Merkblatt.

* Rating according to EN 1092-1:2018.

PMO – Maximum operating pressure for saturated steam: 13 bar.

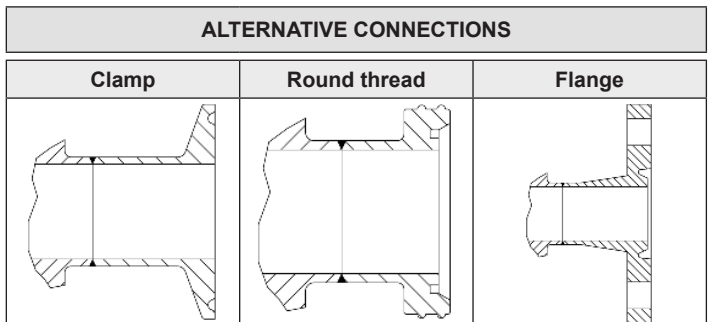
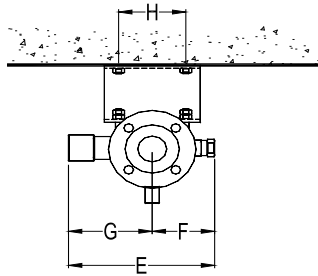
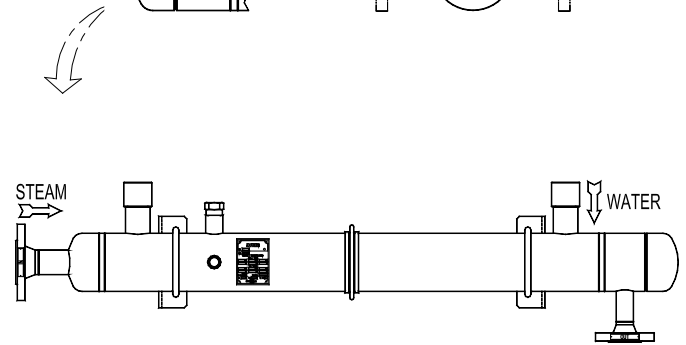
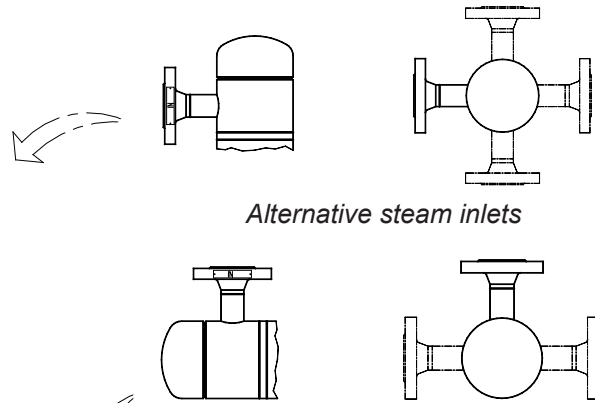
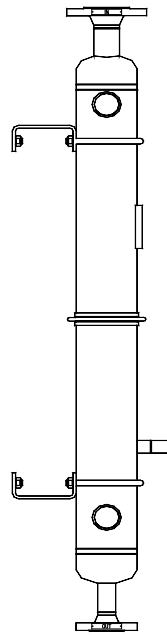
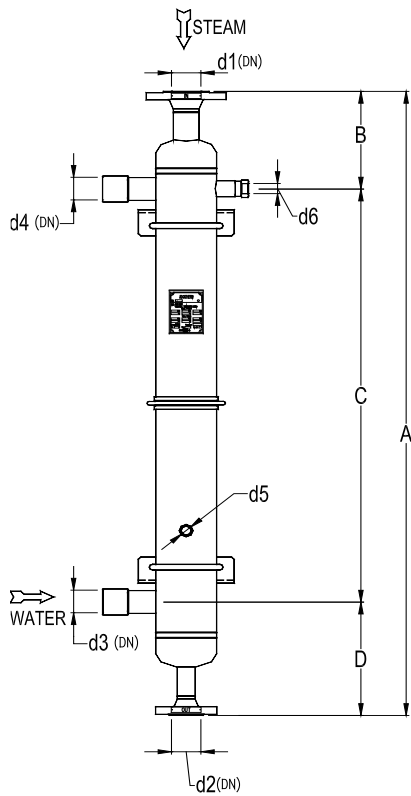

Different designs and dimensions on request.

DIMENSIONS (mm)														
MODEL	A	B	C	S	E	F	G	H	d1 *	d2 *	d3 *	d4 *	d5	d6
STSV 3.075	1045	225	595	225	250	105	145	100	40	25	11/2"	11/2"	1/2"	3/4"
STSV 3.100	1295	225	845	225	250	105	145	100	40	25	11/2"	11/2"	1/2"	3/4"
STSV 3.150	1795	225	1345	225	250	105	145	100	40	25	11/2"	11/2"	1/2"	3/4"
STSV 4.075	1075	240	595	240	274	117	157	125	40	25	11/2"	11/2"	1/2"	3/4"
STSV 4.100	1325	240	845	240	274	117	157	125	40	25	11/2"	11/2"	1/2"	3/4"
STSV 4.150	1825	240	1345	240	274	117	157	125	40	25	11/2"	11/2"	1/2"	3/4"
STSV 5.075	1098	251,5	595	251,5	300	130	170	154	50	40	2"	2"	1/2"	3/4"
STSV 5.100	1348	251,5	845	251,5	300	130	170	154	50	40	2"	2"	1/2"	3/4"
STSV 5.150	1848	251,5	1345	251,5	300	130	170	154	50	40	2"	2"	1/2"	3/4"
STSV 6.075	1126	265,5	595	265,5	330	145	185	182	65	40	2"	2"	1/2"	3/4"
STSV 6.100	1376	265,5	845	265,5	330	145	185	182	65	40	2"	2"	1/2"	3/4"
STSV 6.150	1876	265,5	1345	265,5	330	145	185	182	65	40	2"	2"	1/2"	3/4"
STSV 8.075	1136	280,5	595	280,5	380	170	210	232	80	50	2 1/2"	2 1/2"	1/2"	3/4"
STSV 8.100	1406	280,5	845	280,5	380	170	210	232	80	50	2 1/2"	2 1/2"	1/2"	3/4"
STSV 8.150	1906	280,5	1345	280,5	380	170	210	232	80	50	2 1/2"	2 1/2"	1/2"	3/4"

* Merely indicative values. Final sizes will be determined after order, considering the effective flow rates.

TYPICAL INSTALLATION AS FLASH STEAM VENT CONDENSER (Steam to the shell)

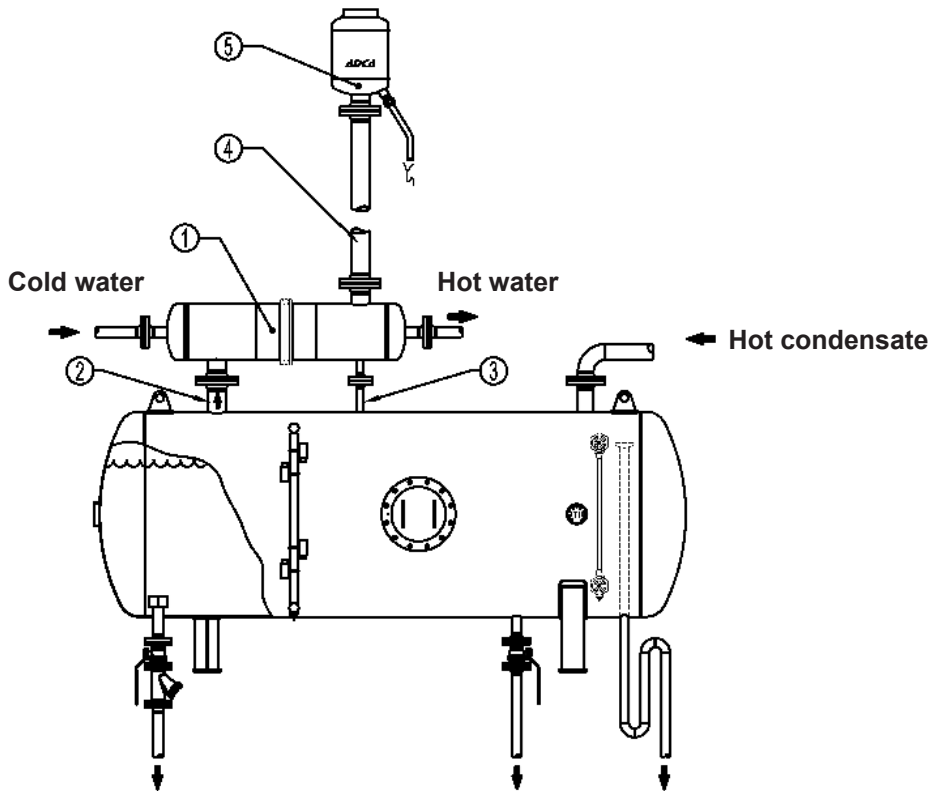

POS. N°	MATERIAL
1	STS heat exchanger
2	Receiver vent
3	Drain (condensate)
4	Vent to atmosphere
5	EH - Exhaust head

Flash steam vents energy recovery. When heating water or another process fluid using this steam, which is usually wasted, both boiler operation period and energy consumption are reduced, consequently reducing the pollution emissions as well.

TYPICAL INSTALLATION AS PART OF A "PWHU" (Packaged Water Heating Unit)

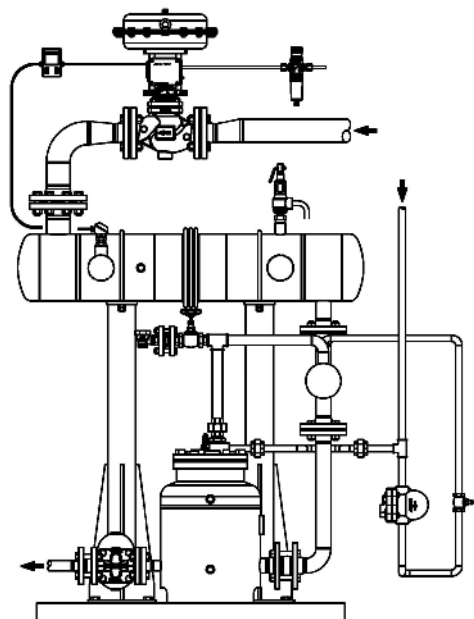

The PWHU unit allows several options for the preparation of hot water for consumption or heating. It can be supplied complete with the feed water system, expansion and recirculation for closed circuit operation, or simply prepared to supply process hot water.

For drawing simplifying purposes some components and accessories have been omitted.