

**ADCAMAT PRESSURE OPERATED PUMP
PPA14
DN 80 x 50**

DESCRIPTION

The ADCAMAT PPA (Pressure Operated Pump), fabricated in carbon steel (stainless steel on request), is recommended in the transfer of high temperature liquids such as condensate, oils and others, to a higher elevation or pressure.

Under certain conditions, it can drain a closed vessel under vacuum or pressure.

The pump can be operated by steam, compressed air or other gases, and can be used for lifting any kind of non-corrosive liquids.



OPERATION

Liquid flows by gravity into the pump through an inlet check valve lifting a float which, at the upper limit of its stroke, opens the supply valve, allowing steam or compressed air to enter the pump's body. Pressure in the pump builds up until it's just sufficient to overcome back pressure.

The pressurized liquid opens the outlet check valve and discharge begins. When the float reaches the minimum lower level, it closes the steam or compressed air supply valve and opens the vent, allowing the liquid to fill the pump again.

As the amount of liquid discharged at each stroke is known, the total volume that flows during a given period of time can be calculated by counting the number of cycles during that period. For that purpose, a special counter is available which screws into a tapped connection on the top cover of the pump. This counter records the number of pumping strokes, thus enabling the pump to function as a reliable flow meter.

MAIN

FEATURES: No electric requirements.

OPTIONS: Duplex packaged design.
Stainless steel construction.
Level gauge.
Stroke counter.

USE: To lift hot condensate or other liquids.

AVAILABLE

MODELS: PPA14 – Carbon steel construction.
(Sandblasted, metalized and black painted).

SIZES: DN 80 x 50.

CONNECTIONS: Flanged EN1092-1 PN16.
Flanged ANSI B16.5 class 150 lb.
Female threaded ISO 7 Rp.
Special flanges on request.

INSTALLATION: Horizontal installation.
See IMI – Installation and maintenance instructions.

MOTIVE GAS: Steam or compressed air.

LIMITING CONDITIONS	
Minimum density	0,80 kg/L
Maximum viscosity	5 °Engler
Maximum motive pressure	10 bar
Minimum motive pressure	1 bar
Pump discharge per cycle	25 L

BODY LIMITING CONDITIONS *		
	ALLOWABLE PRESSURE	RELATED TEMPERATURE
PN16	16 bar	50 °C
	15 bar	100 °C
	12,7 bar	200 °C
	12 bar	250 °C
ANSI 150 lb	16 bar	50 °C
	12,6 bar	200 °C

Min. operating temp.: -10 °C; Design code: ASME VII.

* Rating according to EN 1092-1:2018.

CE MARKING – GROUP 2 (PED – European Directive)	
PN16	Category
DN 80 x 50	3 (CE marked)

DIMENSIONS (mm)

SIZE DN	A PN16	A 150 lb	B PN16	B 150 lb	C	D	E	F	H	J	L	M	WGT. (kg)	VOL. (L)
80 x 50	775	847	580	616	113	665	406	200	642	30	30	435	123	68

* A – with welding neck EN 1092-1 flanges. Dimensions are different if threaded flanges are requested.

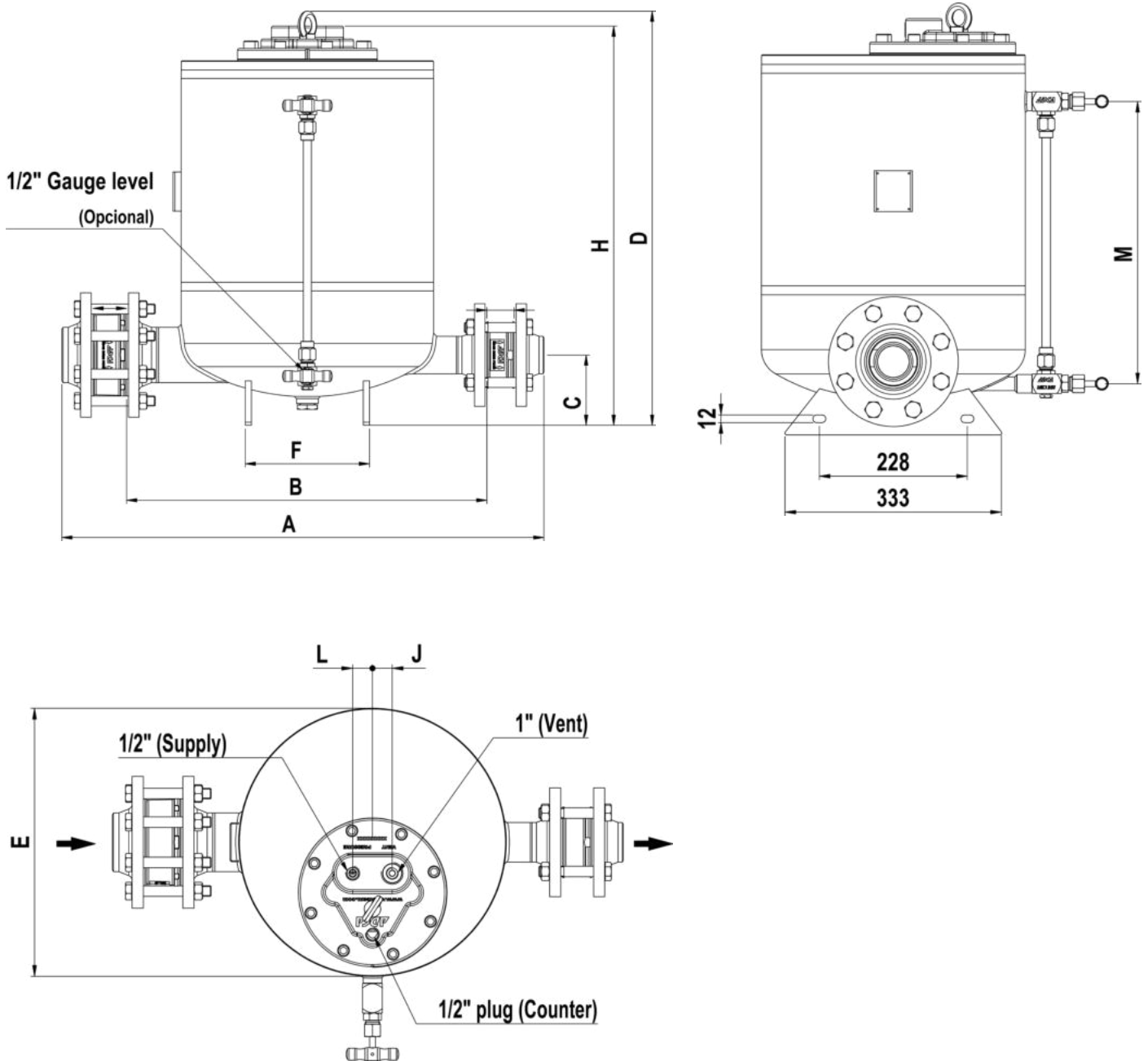

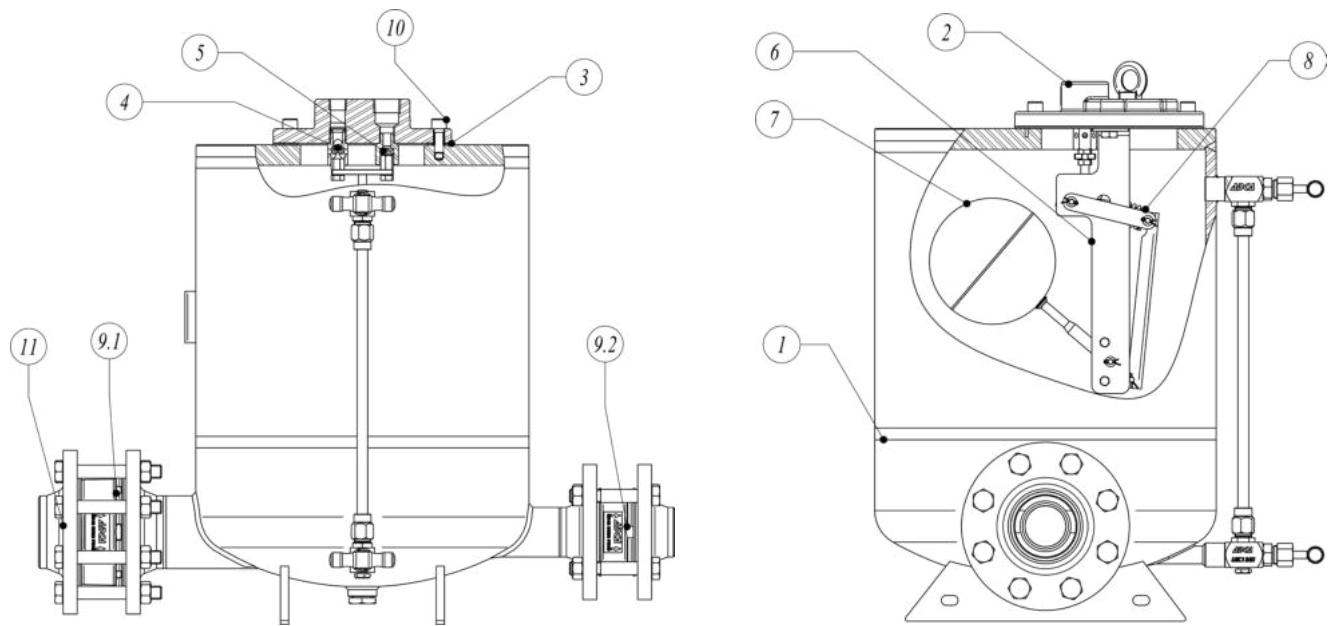

MATERIALS		
POS. N°	DESIGNATION	MATERIAL
1	Pump body	P265GH / 1.0425; P235GH / 1.0345; S235JR / 1.0038
2	Cover	GJS-400-15 / 0.7040 ; A216 WCB / 1.0619
3	* Cover gasket	Non asbestos
4	* Inlet valve / Seat assembly	Stainless steel
5	* Exhaust valve / Seat assembly	Stainless steel
6	Internal mechanism	Stainless steel
7	* Float	Stainless steel
8	* Spring assembly (2 pieces)	Inconel
9.1	* RD40 outlet check valve	A351 CF8M / 1.4408
9.2	* RD40 Inlet check valve	A351 CF8M / 1.4408
10	Bolts	Steel 8.8
11	** PN16 EN 1092-1 flanges	P250GH / 1.0460

* Available spare parts.

** Welding neck EN 1092-1:2018 flanges. Threaded flanges on request.

STROKE COUNTER

Available on request, it can be screwed directly into the top cover of the pump or above the pump, through a 1/2" size pipe for easier reading (max. 1 m).

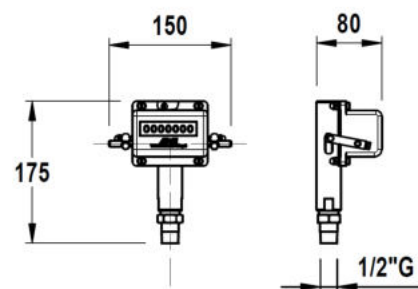

SIZING AND INSTALLATION

SIZING OF THE SYSTEM

The discharge capacity of the pump is a function of:

1. Condensate load (kg/h).
2. The pressure of the operating medium (steam, compressed air or other gases).
3. The total lift or back pressure the pump will have to overcome. This includes the change in fluid level elevation after the pump (0.0981 bar/m of lift), plus pressure in the return piping, plus the pressure drop in bar caused by pipe friction, plus any other system component pressure drop the pump exhaust will have to overcome (barg).
4. Filling head available (300 mm is recommended).

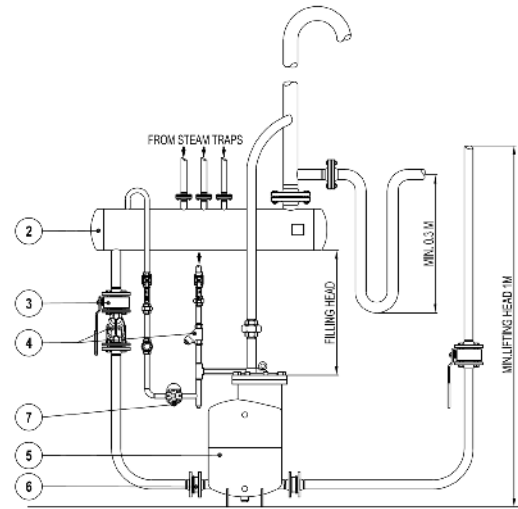

Fig.1

INSTALLATION

Fig.1 shows a typical installation example of an ADCAMAT pump. For further details and instructions, please contact manufacturer.

MATERIALS			
POS.	DESIGNATION	POS.	DESIGNATION
2	Receiver	5	Pump
3	Ball valve	6	RD40 disc check valve
4	Strainer	7	Steam trap

Table 1

RECEIVER

A receiver is recommended to temporarily hold the liquid and prevent any flooding of the equipment, while the pump is performing a pumping cycle. A length of pipe of large diameter can be used.

SUGGESTED RECEIVER	
Pump size	80 x 50
Receiver size Diam x lenght	323 x 1000

Table 2

CAPACITY CORRECTION FACTOR FOR GASES OTHER THAN STEAM					
% Backpress. vs Motive press. (BP/MP)	10%	30%	50%	70%	90%
Correction factor	1,04	1,08	1,12	1,18	1,28

Table 3

CAPACITY MULTIPLYING FACTORS FOR OTHER FILLING HEADS				
Pump size DN	Filling head (mm)			
	150	300	600	900
80 x 50	0,9	1	1,08	1,2

Table 4

FLOW RATE (kg/h) Installation with 300 mm filling head above the pump cover		
Motive pressure (bar)	Total lift (bar)	DN 80 x 50
1	0,35	3710
1,7		5470
3,5		5820
5		5970
7		6010
10		6290
1,7	1	3570
3,5		5160
5		5360
7		5470
10	5790	
2,5	1,5	3435
3,5		4835
5		4980
7		5080
10	5390	
3,5	3	2890
4		3440
5		3780
7		4040
10	4430	
4,5	4	2505
5		2680
7		2990
10		3385

Table 5 (based on liquid specific gravity 0,9 – 1,0).
 Filling head measured from the bottom of receiver to top of pump cover.

Example:

Condensate load	3500 kg/h
Filling head	150 mm
Motive fluid	Compressed air
Available pressure	7 bar
Vertical lift after pump	10 m
Return piping pressure	1,2 bar
Piping friction pressure drop	Negligible

Calculations:

Total back pressure: $1,2 \text{ bar} + (10 \text{ m} \times 0,0981) = 2,181 \text{ bar}$.
 Pump choice, assuming steam as motive fluid, at a pressure of 7 bar and a back pressure of 3 bar: the DN 80 x 50 pump has a capacity of 4040 kg/h, according to Table 5, so it is the one we should select.

Correction for filling Head:

With 150 mm filling head the correction factor from Table 4 is 0,9. The corrected capacity is:
 $4040 \text{ kg/h} \times 0,9 = 3636 \text{ kg/h}$.

Correction for air as a motive fluid:

The % back pressure $2,181 \text{ bar} / 7 \text{ bar} = 31\%$
 The correction factor from table 3, is 1,08.
 The corrected capacity is $3636 \text{ kg/h} \times 1,08 = 3926,88 \text{ kg/h}$,
 and so, the DN 80 x 50 pump is still recommended.

TYPICAL APPLICATIONS

Condensate recovery - open system

The pump removes high temperature condensate without cavitation problems.

WARNING: Vent line must be unrestricted and self draining to the receiver.

MATERIALS			
POS.	DESIGNATION	POS.	DESIGNATION
1	Heat exchanger	5	Pump
2	Receiver	6	RD40 disc check valve
3	Ball valve	7	Steam trap
4	Strainer	8	Air vent

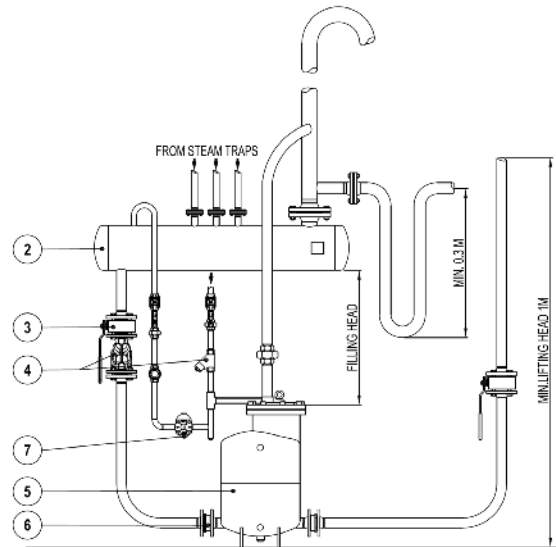

Removal of condensate under pressure with ADCAMat pump and steam trap combination

When the steam pressure is sufficient to overcome back pressure, the trap operates.

If the pressure decreases, then the pressure operated pump starts to work, removing the condensate by pumping through the float steam trap.

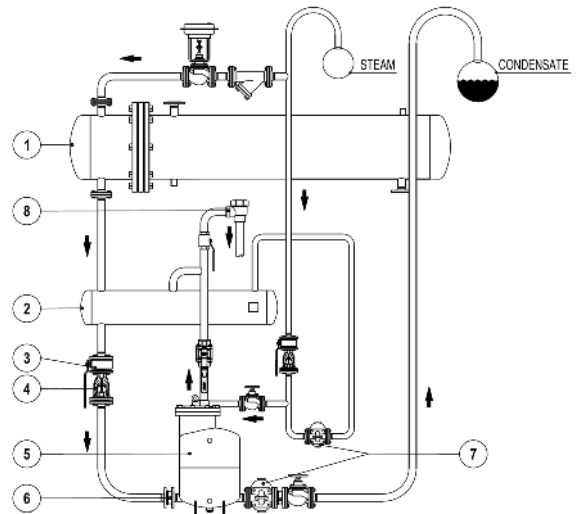

Drainage of a single unit under vacuum (max. 0,2 bar abs)

Head H1 must range between 1 and 2 m. The lift H must be as minimum as possible, but never less than 1 m (otherwise a siphon is required, as shown in H2).

Use steam as operating medium (max. pressure 2 – 3 bar).

