

## ADCAMAT PRESSURE OPERATED PUMP POPS DN 100

### DESCRIPTION

The ADCAMAT POP (Pressure Operated Pump), fabricated in carbon steel (stainless steel on request), is recommended in the transfer of high temperature liquids such as condensate, oils and others, to a higher elevation or pressure.

Under certain conditions, it can drain a closed vessel under vacuum or pressure.

The pump can be operated by steam, compressed air or other gases, and can be used for lifting any kind of non-corrosive liquids.



### OPERATION

Liquid flows by gravity into the pump through an inlet check valve lifting a float which, at the upper limit of its stroke, opens the supply valve, allowing steam or compressed air to enter the pump's body. Pressure in the pump builds up until it's just sufficient to overcome back pressure.

The pressurized liquid opens the outlet check valve and discharge begins. When the float reaches the minimum lower level, it closes the steam or compressed air supply valve and opens the vent, allowing the liquid to fill the pump again.

As the amount of liquid discharged at each stroke is known, the total volume that flows during a given period of time can be calculated by counting the number of cycles during that period. For that purpose, a special counter is available which screws into a tapped connection on the top cover of the pump. This counter records the number of pumping strokes, thus enabling the pump to function as a reliable flow meter.

### MAIN

**FEATURES:** No electric requirements.

**OPTIONS:** Duplex packaged design.  
Stainless steel construction.  
Level gauge.  
Stroke counter.

**USE:** To lift hot condensate or other liquids.

### AVAILABLE MODELS:

POPS – Carbon steel construction.  
(Sandblasted, metalized and black painted).

**SIZES:** DN 100 x 100 (for smaller sizes see IS 9.101E).

**CONNECTIONS:** Flanged EN1092-1 PN16.  
Female threaded ISO 7 Rp (threaded flanges).  
Others on request.

**INSTALLATION:** Horizontal installation.  
See IMI – Installation and maintenance instructions.

**MOTIVE GAS:** Steam, compressed air or other gases.

LIMITING CONDITIONS	
Minimum density	0,80 kg/L
Maximum viscosity	5 °Engler
Maximum motive pressure	10 bar
Minimum motive pressure	1 bar
Pump discharge per cycle	325 L

BODY LIMITING CONDITIONS *		
POPS		
	ALLOWABLE PRESSURE	RELATED TEMPERATURE
PN16	16 bar	50 °C
	14 bar	100 °C
	13 bar	195 °C
	12 bar	250 °C
ANSI 150 lb	16 bar	50 °C
	13 bar	195 °C

Min. operating temp.: -10 °C; Design code: ASME VII.

\* Rating according to EN 1092-1:2018.

CE MARKING – GROUP 2 (PED – European Directive)	
PN16	Category
All sizes	4 (CE marked)

DIMENSIONS (mm)

SIZE DN	A PN16	A 150 lb	B	C	D	E	F	G	H	I	J	M	WGT. (kg)	VOL. (L)
100 X 100 4" X 4"	1705	1760	1473	229	1200	900	715	753	960	564	95	710	565	1028

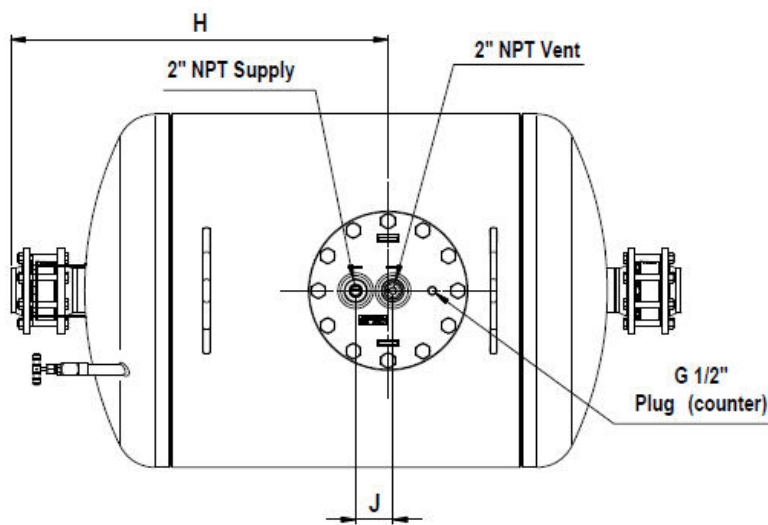
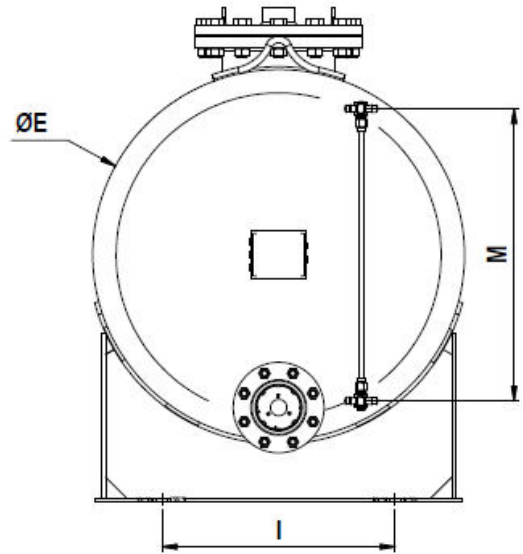
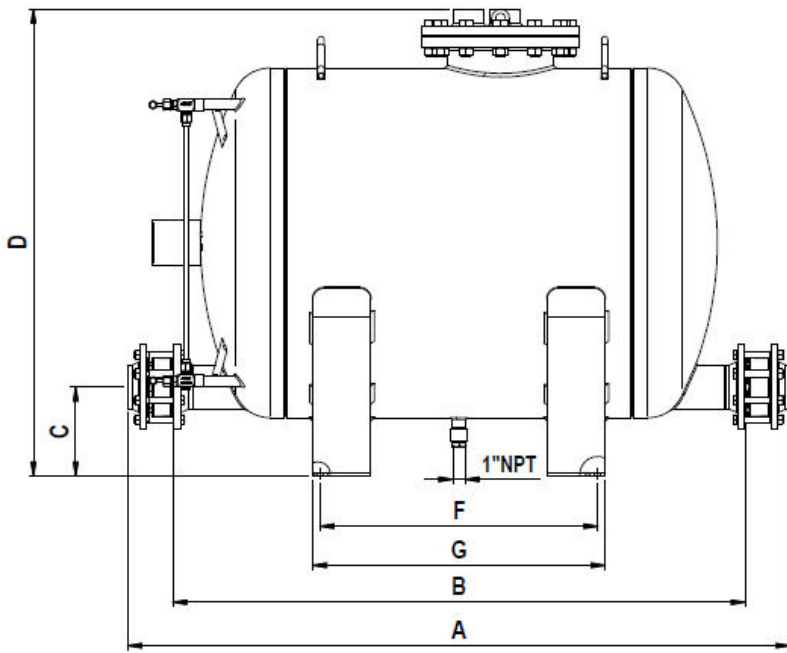

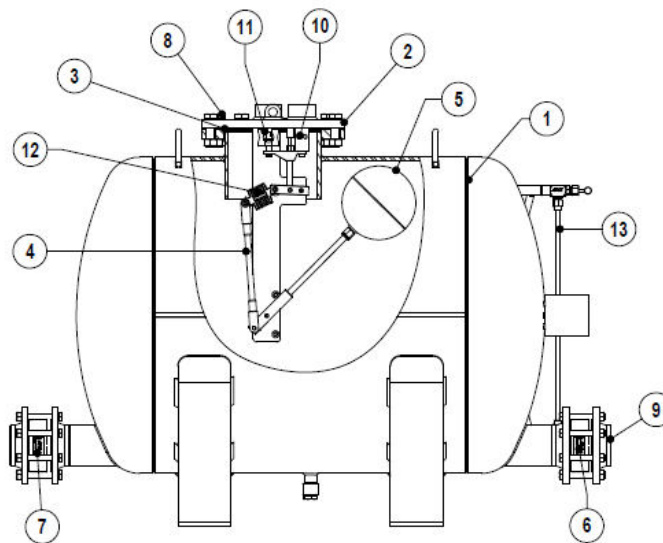

MATERIALS		
POS. N°	DESIGNATION	POPS
1	Pump body	P265GH / 1.0425 ; P235GH / 1.0345 ; S235JR / 1.0038
2	Cover	GJS-400-15 / 0.7040
3	* Cover gasket	Non asbestos
4	Internal mechanism	Stainless steel
5	* Float	Stainless steel
6	* RD40 Outlet check valve	CF8M / 1.4408
7	* RD40 Inlet check valve	CF8M / 1.4408
8	Bolts	Steel 8.8
9	** PN16 EN 1092-1 Flanges	P250GH / 1.0460
10	* Motive inlet valve / Seat assy.	Stainless steel
11	* Exhaust valve / Seat assy.	Stainless steel
12	* Springs	INCONEL
13	*** Level gauge cocks / Glass	See catalog IS LGC 135.10

\* Available spare parts.

\*\* Welding neck EN 1092-1:2018 flanges. Threaded flanges on request.

\*\*\* Optional.

## STROKE COUNTER

Available on request, it can be screwed directly into the top cover of the pump or above the pump, through a 1/2" size pipe for easier reading (max. 1 m).

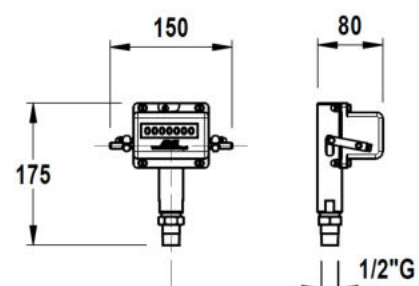

## SIZING AND INSTALLATION

### SIZING OF THE SYSTEM

The discharge capacity of the pump is a function of:

1. Condensate load (kg/h).
2. The pressure of the operating medium (steam, compressed air or other gases).
3. The total lift or back pressure the pump will have to overcome. This includes the change in fluid level elevation after the pump (0.0981 bar/m of lift), plus pressure in the return piping, plus the pressure drop in bar caused by pipe friction, plus any other system component pressure drop the pump exhaust will have to overcome (barg).
4. Filling head available (300 mm is recommended).

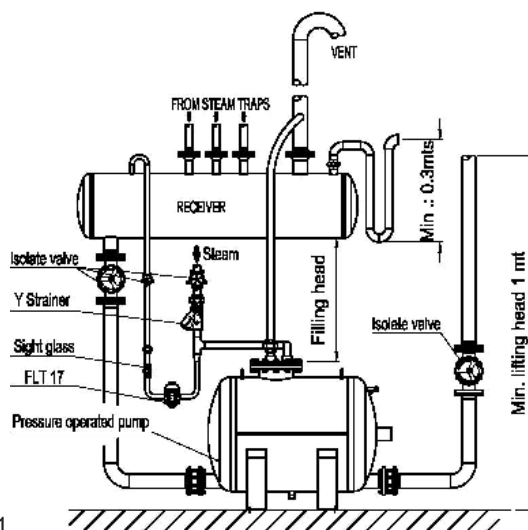

Fig.1

### INSTALLATION

Fig.1 shows a typical installation example of an ADCAMAT POPS. For further details and instructions, please contact manufacturer.

### RECEIVER

A receiver is recommended to temporarily hold the liquid and prevent any flooding of the equipment, while the pump is performing a pumping cycle. A length of pipe of large diameter can be used.

SUGGESTED RECEIVER			
Pump size	DN 100 x 100		
Pipe size with 1 m lenght	406 x 2000	640 x 1500	800 x 1500

Table 2

CAPACITY CORRECTION FACTOR FOR GASES OTHER THAN STEAM					
% Backpress. vs Motive press. (BP/MP)	10%	30%	50%	70%	90%
Correction factor	1,04	1,08	1,12	1,18	1,28

Table 3

CAPACITY MULTIPLYING FACTORS FOR OTHER FILLING HEADS				
Pump size DN	Filling head (mm)			
	150	300	600	900
DN 100 x 100	0,7	0,8	1	1,08

Table 4

FLOW RATE (kg/h) Installation with 300 mm filling head above the pump cover		
Motive pressure (bar)	Total lift (bar)	DN 100 x 100
1	0,35	13130
1,7		16850
3,5		21900
5		24830
7		26880
10		29800
1,7	1	16630
3,5		20400
5		23050
7		25100
10	29800	
2,5	1,5	13210
3,5		15150
5		17280
7		19100
10		21410
3,5	3	11860
4		12300
5		12900
7		13740
10		14980
4,5	4	11700
5		11840
7		12710
10		13760

Table 5 (based on liquid specific gravity 0,9 – 1,0).

**Example:**

Condensate load	8500 kg/h
Filling head	150 mm
Motive fluid	Compressed air
Available pressure	7 bar
Vertical lift after pump	10 m
Return piping pressure	1,2 bar
Piping friction pressure drop	Negligible

**Correction for filling Head:**

With 150 mm filling head the correction factor from Table 4 is 0,7. The corrected capacity is:  
 13740 kg/h x 0,7 = 9618 kg/h.

**Calculations:**

Total back pressure: 1,2 bar + (10 m x 0,0981) = 2,181 bar.  
 Pump choice, assuming steam as motive fluid, at a pressure of 7 bar and a back pressure of 3 bar: the DN 100 pump has a capacity of 13740 kg/h, according to Table 5, so it is the one we should select.

**Correction for air as a motive fluid:**

The % back pressure 2,181 bar / 7 bar = 31%  
 The correction factor from table 3, is 1,08.  
 The corrected capacity is 9618 kg/h x 1,08 = 10387,44 kg/h,  
 and so, the DN 100 pump is still recommended.