

**ADCAMAT PACKAGED AUTOMATIC PUMP  
(Suitable for steam supply)  
POPS-KT (Triplex)**

**DESCRIPTION**

The POPS-K packaged pump units can be used to lift or displace hot condensate and other liquids even in hazardous areas.

A POPS-KT (Triplex) packaged unit is comprised by three Adcamat pumps in parallel, a vented receiver and all auxiliary items, compactly mounted on a metal frame, piped and ready for connection.

For operating conditions and pumping capacities, please refer to the information sheet IS 9.101 E.

All connections are flanged EN 1092-1 PN16. Threaded flanges and/or other connection standards available on request.

How to order: i.e. ADCAMAT POPS-KT carbon steel packaged pump, steam operated, flanged PN16 DN 80x50.



CE MARKING – GROUP 2 (PED – European Directive)	
PN16	Category
All sizes	2 (CE marked)

MATERIALS	
POS. N°	DESIGNATION
1	POPS pump
2	Receiver
3	MWS1 wafer ball valve
4	IS16F strainer
5	RD40 disc check valve
6	M3i ball valve
7	Overflow
8	IS140 Y strainer
9	UCX41 + UBS20 steam trap
10	Metal frame

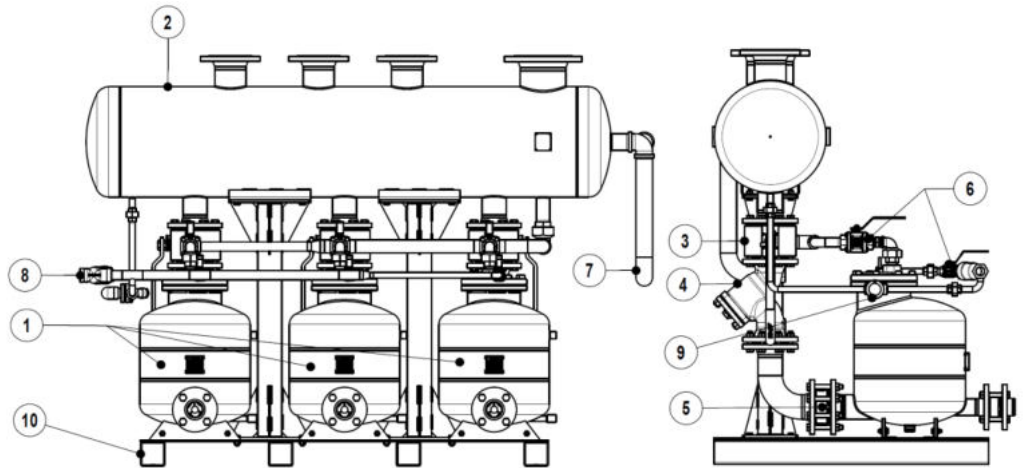

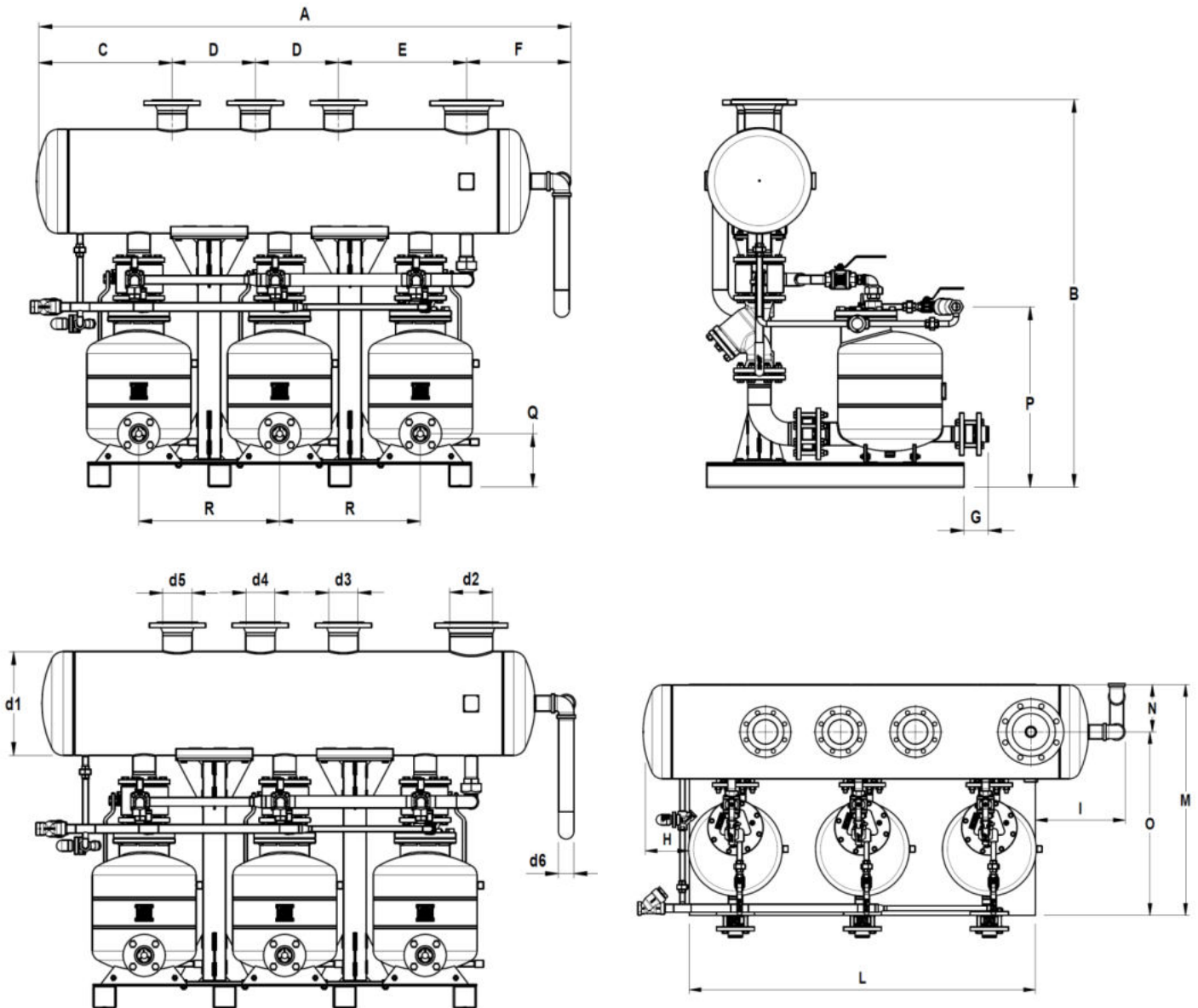

**LIMITING CONDITIONS:**  
Receiver - Max. operating pressure: 0,5 bar.  
Pump: See IS 9.101 E.

CONNECTIONS SIZE						
DN	d1	d2	d3	d4	d5	d6
3 x DN 80x50	406	150	DN 100	DN 100	DN 100	2"

d2 – vent; d3, d4 and d5 – condensate inlets; d6 – overflow.

DIMENSIONS (mm)																	
DN	A	B	C	D	E	F	G	H	I	J	L	M	N	O	P	Q	R
3 x DN 80x50	2088	1509	530	325	500	408	95	200	388	0	1500	1000	205	795	709	208	550

Dimensions subject to change without notice. Consult factory for certified dimensions and weight.