

**ADCAMAT PACKAGED AUTOMATIC PUMP  
(Suitable for steam supply)  
POPS-K (Simplex)**

**DESCRIPTION**

The POPS-K packaged pump units can be used to lift or displace hot condensate and other liquids even in hazardous areas.

A POPS packaged unit is comprised by an Adcamat pump, a vented receiver and all auxiliary items, compactly mounted on a metal frame, piped and ready for connection. Packaged units save time, work and site costs. In addition, they ensure that the installation of the pump is correct in every detail.

Two or more units can be connected in parallel to cope with flow rates beyond the capacity of a single pump.

Packaged units for operation with compressed air are also available.

All connections are flanged EN 1092-1 PN16.

Threaded flanges and/or other connection standards available on request.

For operating conditions and pumping capacities, please refer to the information sheet IS 9.101 E.

How to order: i.e. ADCAMAT POPS-K carbon steel packaged pump, steam operated, flanged PN16 DN 40.



**CE MARKING – GROUP 2 (PED – European Directive)**

PN16	Category
All sizes	2 (CE marked)

MATERIALS	
POS. Nº	DESIGNATION
1	POPS pump
2	Receiver
3	MWS1 wafer ball valve
4	IS16F strainer
5	RD40 disc check valve
6	Overflow
7	IS140 Y strainer
8	UCX41 + UBS20 steam trap
9	Metal frame

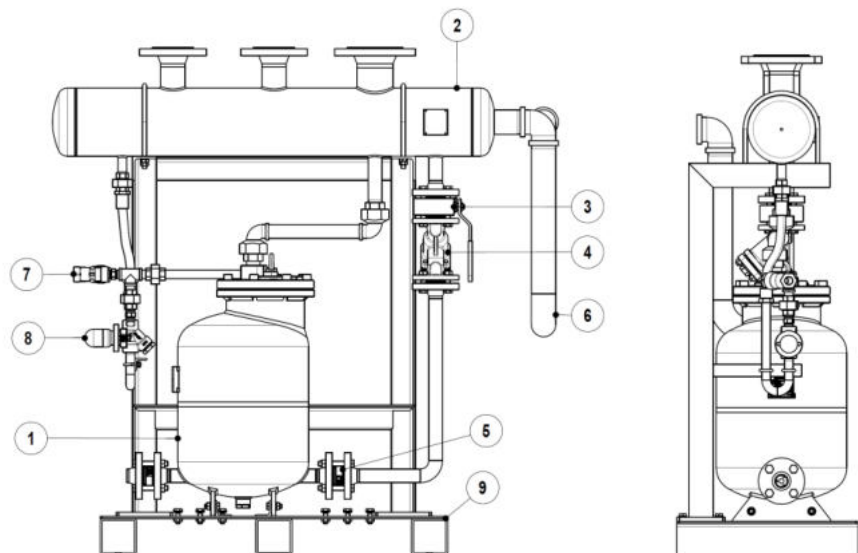

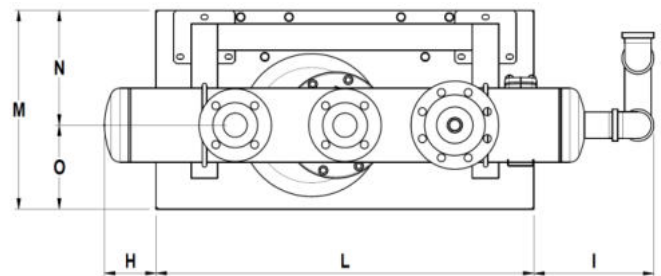
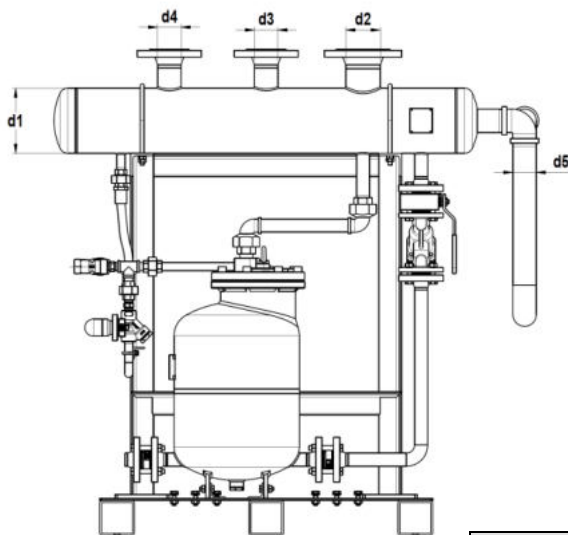
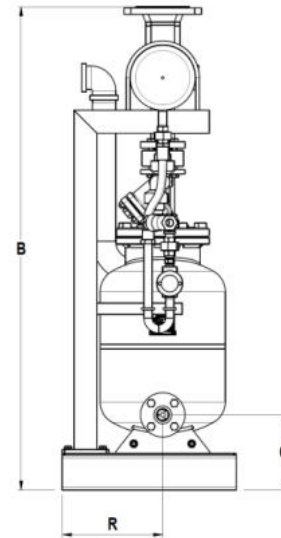
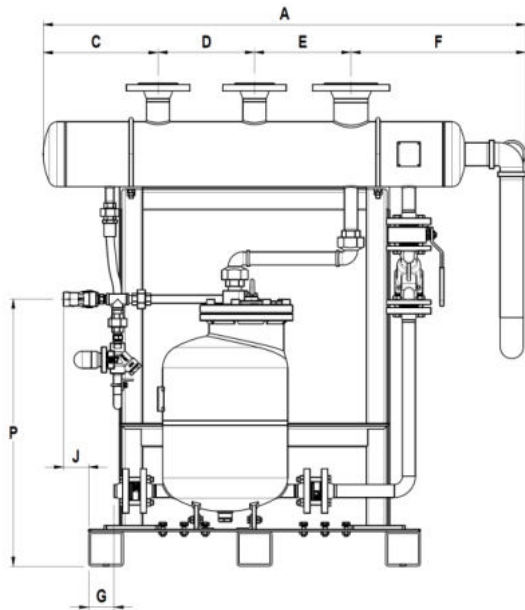

**LIMITING CONDITIONS:**  
Receiver – Max. operating pressure: 0,5 bar.  
Pump: See IS 9.101 E.

DIMENSIONS					
DN	d1 (mm)	d2 *	d3 *	d4 *	d5
25	168	DN 80 – 3"	DN 50 – 2"	DN 50 – 2"	2"
40	168	DN 80 – 3"	DN 50 – 2"	DN 50 – 2"	2"
50	220	DN 80 – 3"	DN 50 – 2"	DN 50 – 2"	2"
80 x 50	273	DN 100 – 4"	DN 65 – 2 1/2"	DN 65 – 2"	2"

d2 – vent; d3 and d4 – condensate inlets; d5 – overflow.  
\* Threaded inlets optional.

DIMENSIONS (mm)																	
SIZE DN	A	B	C	D	E	F	G	H	I	J	L	M	N	O	P	Q	R
25	1251	1254	298	250	250	454	66	118	274	66	860	450	260	190	693	195	260
40	1251	1254	298	250	250	454	46	118	274	66	860	450	260	190	693	195	260
50	1289	1304	316	250	250	473	32	136	293	72	860	450	260	190	693	195	260
80 x 50	1367	1368	175	330	330	532	13	125	282	3	960	535	309	226	703	208	309

Dimensions subject to change without notice. Consult factory for certified dimensions and weight.