

## PRESSURE SUSTAINING VALVE PS45 (EN)

### DESCRIPTION

The ADCA PS45 series pressure sustaining valves are single seat bellows sealed controllers, operating without auxiliary energy, designed for use with steam, compressed air, and other gases compatible with the construction.

They are particularly suitable for sustaining steam pressure in all energy and process systems where minimum upstream pressures must be kept under control.

### OPERATION

Pressure sustaining is achieved by variable throttling of the inlet flow at the valve seat by variation of the flow area between seat and disc. The inlet pressure which is transmitted through the sensing line to the diaphragm or piston chamber counteracts the spring force acting on the valve spindle and controls the valve aperture corresponding to the spring setting and, thus, to the required inlet pressure.

### MAIN FEATURES

Specially designed high durability bellows, providing pressure balancing and frictionless plug stem.

Robust construction (fit-and-forget).

Suitable for use with high pressure turndowns.

Interchangeable actuators.

**OPTIONS:** Soft sealing in PTFE/GR for use with steam.  
Nitrile rubber soft seated version for air and gas applications where tight shut-off is required.

**USE:** Steam, compressed air and other gases compatible with the construction.

**AVAILABLE MODELS:** PS45G and PS45GT or N – PN16 SG iron.  
PS45S and PS45ST or N – PN16 Cast steel.  
PS45I and PS45IT or N – PN40 Cast steel.  
PS45L and PS45LT or N – Stainless steel.

(All wetted parts free of ferrous metal or in stainless steel.)

Suffix T: soft seated with PTFE/GR.

Suffix N: soft seated with nitrile rubber.

**SIZES:** DN 15 to DN 100.

**CONNECTIONS** PS45G Flanged EN 1092-2 PN16.  
PS45S or I Flanged EN 1092-1 PN16 – PN40.  
ANSI B16.5 flanged connections on request.

**INSTALLATION:** Horizontal installation.  
An “Y” strainer, humidity separator and steam trap should be installed upstream of the valve.

See IMI – Installation and maintenance instructions.

**Warning: sustaining valves are not substitute of safety valves or vacuum relief valves!**



CE MARKING – GROUP 2 (PED – European Directive)		
PN16	PN40	Category
DN 15 to DN 50	DN 15 to DN 32	SEP
DN 50 to DN 100	DN 40 to DN 100	1 (CE marked)

**LIMITING CONDITIONS**

Valve model	PS45G PS45S	PS45S	PS45I	PS45GT PS45ST	PS45ST	PS45IT	PS45GN* PS45SN*	PS45SN*	PS45IN*
Body design conditions	PN16	PN40	PN40	PN16	PN40	PN40	PN16	PN40	PN40
Maximum upstream pressure **	13 bar	13 bar	13 bar	13 bar	13 bar	13 bar	13 bar	13 bar	13 bar
Maximum downstream pressure	13 bar	13 bar	13 bar	13 bar	13 bar	13 bar	13 bar	13 bar	13 bar
Minimum downstream pressure	0,15 bar	0,15 bar	0,15 bar	0,15 bar	0,15 bar	0,15 bar	0,15 bar	0,15 bar	0,15 bar
Maximum operating temperature	200 °C	250 °C	250 °C	200 °C	200 °C	200 °C	80 °C	80 °C	80 °C
Maximum reducing ratio	25:1	25:1	25:1	25:1	25:1	25:1	10:1	10:1	10:1
Rangeability	10:1	10:1	10:1	10:1	10:1	10:1	10:1	10:1	10:1
Maximum cold hydraulic test	24 bar	25 bar	25 bar	24 bar	25 bar	25 bar	24 bar	25 bar	25 bar
Max. hydraul. factory valve body test	24 bar	60 bar	60 bar	24 bar	60 bar	60 bar	24 bar	60 bar	60 bar

\* Suffix N: a maximum turndown ratio 10:1 should be observed. Other soft materials on request.

\*\* Others, with bellows or piston actuator, available on request.

**DIMENSIONS (mm)**

VALVE				ACTUATOR		
SIZE DN	A	B	WGT. (kg)	TYPE	C	WGT. (kg)
15	130	440	12,7	A1	172	4,3
20	150	440	12,7	A11	172	4,3
25	160	440	13,7	A2	220	7,3
32	180	445	15,7	A21	220	7,3
40	200	445	17,7	A3	282	11,3
50	230	540	25,7	A4	340	16,3
65	290	540	29,7	-	-	-
80	310	610	36,7	-	-	-
100	350	650	53,7	-	-	-

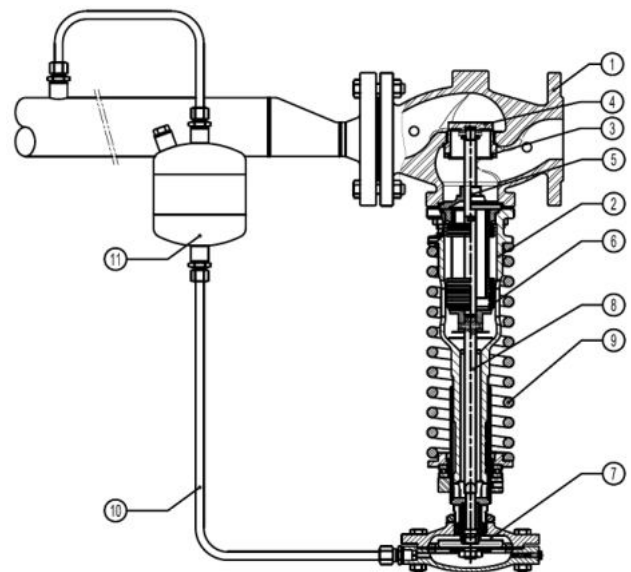
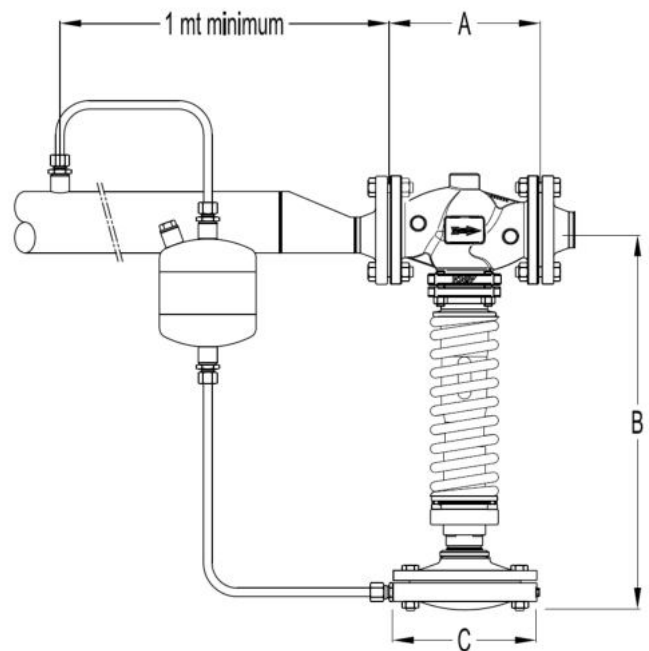

**MATERIALS**

POS. N°	DESIGNATION	MATERIAL
1	Valve body PS45G	GJS-400-15 / 0.7040
1	Valve body PS45S	A216WCB / 1.0619
1	Valve body PS45I	CF8M / 1.4408
2	Piston body PS45G/S	GJS-400-15 / 0.7040
2	Piston body PS45I	GJS-400-15 / 0.7040 nickel plated
3	Valve seat	Stainless steel
4	* Valve disc	Hardened stainless steel
4	* Soft valve disc	AISI 304 / 1.4301; NBR (PTFE/GR, etc.)
5	Guide	AISI 304 / 1.4301
6	* Bellows	AISI 316 Ti / 1.4571
7	* Diaph. chamber PS45G/S	GJL-250 / 0.6025
7	* Diaph. chamber PS45I	CF8M / 1.4408
8	Spindle	AISI 304 / 1.4301
9	Regulating spring	Spring steel
10	* Impulse line PS45G/S	Copper
10	* Impulse line PS45I	AISI 316 / 1.4401
11	** Water seal pot PS45S	S235JRG2 / 1.0038
11	** Water seal pot PS45I	AISI 316 / 1.4401

\* Available spare parts.

\*\* Unnecessary when operating with low temperatures. For detailed information, consult IS POT.10 E.

CAPACITIES									
Valve size (DN)	15	20	25	32	40	50	65	80	100
Kvs (m <sup>3</sup> /h)	4,8	6,9	9,1	11,8	14,4	26,5	51,5	79,5	129,5

**ORDER REQUIREMENTS**

For the optimum selection of valve and actuator it is recommended that valve spring and actuator selection is made by the factory or an authorized distributor. For proper selection, the following data should be supplied:

- Type of fluid and temperature (not necessary in case of saturated steam)
- Maximum operating pressure
- Required opening pressure
- Flow rate (maximum and minimum)

Never size the valve according to the pipe diameter in which it has to be fitted but according to the required actual flow. Pipe sizing must also respect the maximum recommended flow velocities according to the medium.

**HOW TO ORDER**

PS45G DN32 PN16 valve complete with spring Nr.60, type A-2 actuator, condensate vessel and copper tube impulse line.

**HOW TO SIZE (using Kvs)**

Please consult formulas on IS PV10.00 E or consult factory.

**INSTALLATION**

The PS45 is designed primarily for steam, compressed air and non inflammable gases. It has limitations when operating with liquids, since the plug closes in the same direction as the fluid flow, which can produce vibrations and water hammer. Please consult the factory for more details.

At service conditions where the temperatures are higher than 100°C, it is necessary to protect the diaphragm against overheating, by using a seal pot.

**Service conditions with temperatures under 100 °C (water seal pot unnecessary):** For operating with gases, the valve is ready to work. If the valve is to be used with liquids, please consult factory. The valve can be installed with the actuator pointing upwards or downwards.

**Service conditions with temperatures above 100 °C:** Fill the seal pot (11) using a funnel (14), until the water emerges from the actuator vent (12) without bubbles. Close the actuator vent screw (12) and proceed to fill the pot until the water reaches the top, then close it with the plug. The valve is now ready to work. The valve must be installed with the actuator pointing downwards.

Upstream aperture set pressure should be adjusted with the key (13). By compressing the spring, its force increases and, consequently, so does the upstream aperture set pressure. By relaxing the spring, its force decreases and so does the upstream aperture set pressure. The valve moves towards closed position when the upstream pressure decreases, closing when it becomes lower than the aperture set pressure.

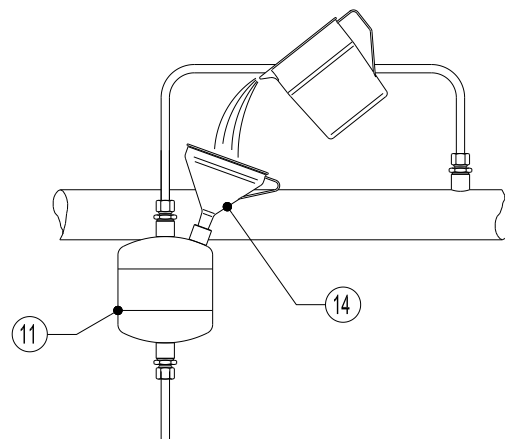
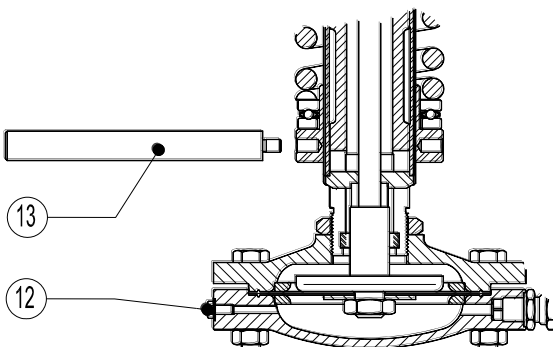

## TYPICAL INSTALLATION

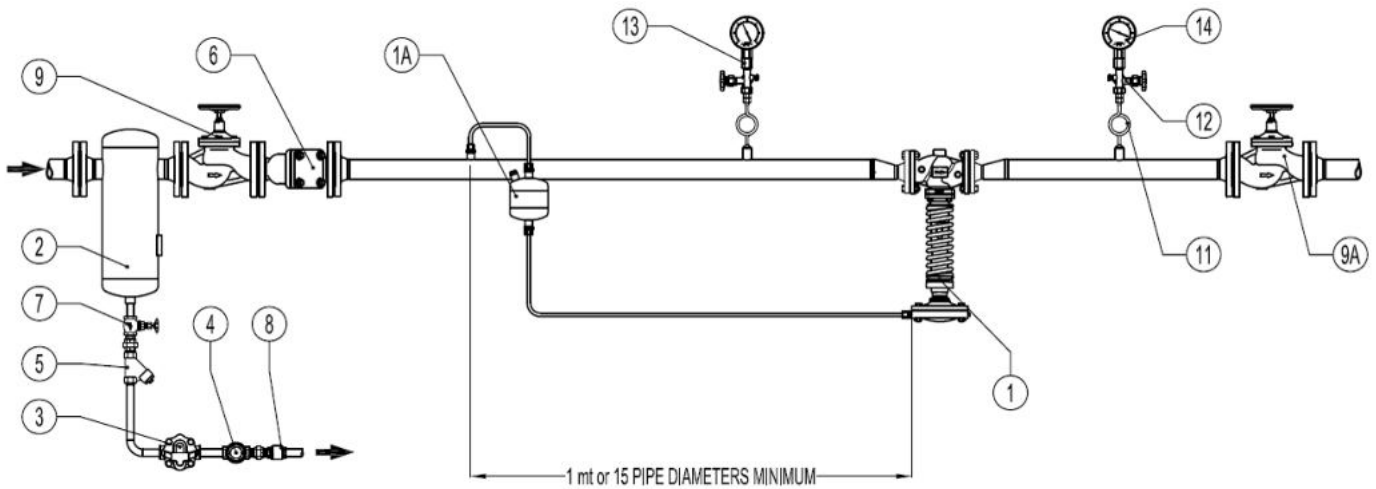

MATERIALS		
POS. N°	DESIGNATION	MODEL
1	Pressure sustaining valve	ADCA PS45
* 1A	Water seal pot	POT
2	Humidity separator	ADCA S25
3	Steam trap	ADCA FLT series
4	Sight glass	ADCA SW12
5	Y strainer	ADCA IS16
6	Y strainer	ADCA IS16F
7	Stop valve	ADCA GV32B
8	Check valve	ADCA RT25
9	Stop valve	ADCA VF16
9A	Stop valve	ADCA VF16
11	Coil	ADCA GSC-40
12	Gauge cock	ADCA GC-400
13	Upstream pressure gauge	ADCA MAN-100
14	Downstream pressure gauge	ADCA MAN-100

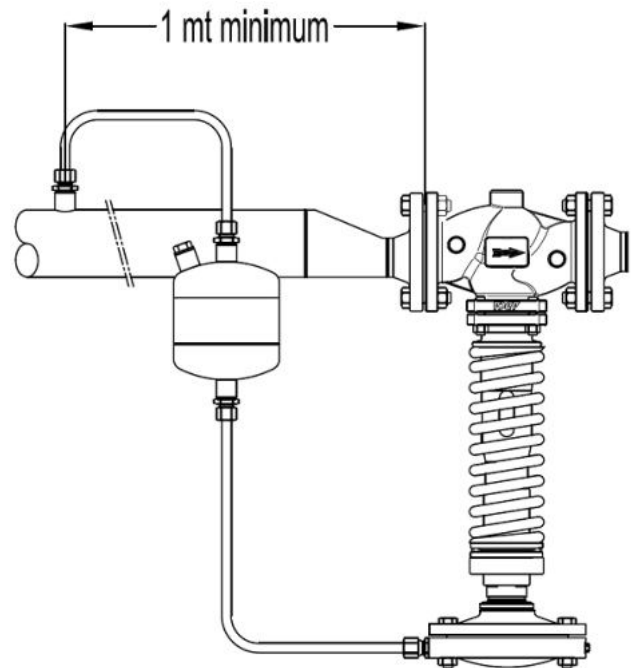

**Remarks:** PN ratings and materials according to the operating pressures.

\* The balance pipe is recommended to be connected in the upstream pipe at a minimum of 1 meter away from the valve. Installation instructions (IMI – PS45) are available, as well as typical assembly drawings. Special assembly designs may be elaborated on request.