

## DIAPHRAGM SENSING PRESSURE REDUCING VALVE P7

### DESCRIPTION

The ADCA P7 series pressure reducing valves are direct acting, spring loaded, diaphragm sensing balanced plug regulators designed for use with steam, nitrogen, compressed air, water and other gases and liquids compatible with the materials of construction.

Particularly suitable for general purpose applications where low flow and high temperatures are involved.

Also specifically recommended to operate as a pilot valve in combination with other pressure regulators.

### MAIN FEATURES

Compact design.  
 Robust stainless steel diaphragm.  
 Precise milibar control.

OPTIONS:            1/4" gauge connection on body.  
                           Top cap (adjustment screw with cover).  
                           External sensing connection.  
                           Low pressure top.  
                           Dome loaded version.  
                           Bar stock stainless steel construction.

USE:                    Steam, compressed air and other gases compatible with the construction.

AVAILABLE MODELS:            P7SS – stainless steel, diaphragm sensing.

SIZES:                 1/4" and 3/8".

CONNECTIONS:      Female threaded ISO 7 Rp or NPT.

INSTALLATION:      Horizontal installation.  
                              See IMI – Installation and maintenance instructions.



CE MARKING – GROUP 2 (PED – European Directive)	
PN 40	Category
1/4" and 3/8"	SEP

FLOW RATE COEFFICIENTS (m <sup>3</sup> /h)		
SIZE	1/4"	3/8"
Kvs	1	1,1

LIMITING CONDITIONS	
Valve model	P7SS
Body design conditions	PN 40
Maximum upstream pressure (steam)	25 bar
Maximum upstream pressure (gases)	31 bar
Maximum downstream pressure	17 bar
Minimum downstream pressure *	0,35 bar
Maximum design temperature	300 °C

\* 0,07 bar with low pressure top (limited at 7 bar inlet).  
 The low pressure diaphragm should be fitted for outlet pressures from 0,07 up to 0,5 bar.  
 Pressure and temperature limiting conditions may change if soft sealing is used.

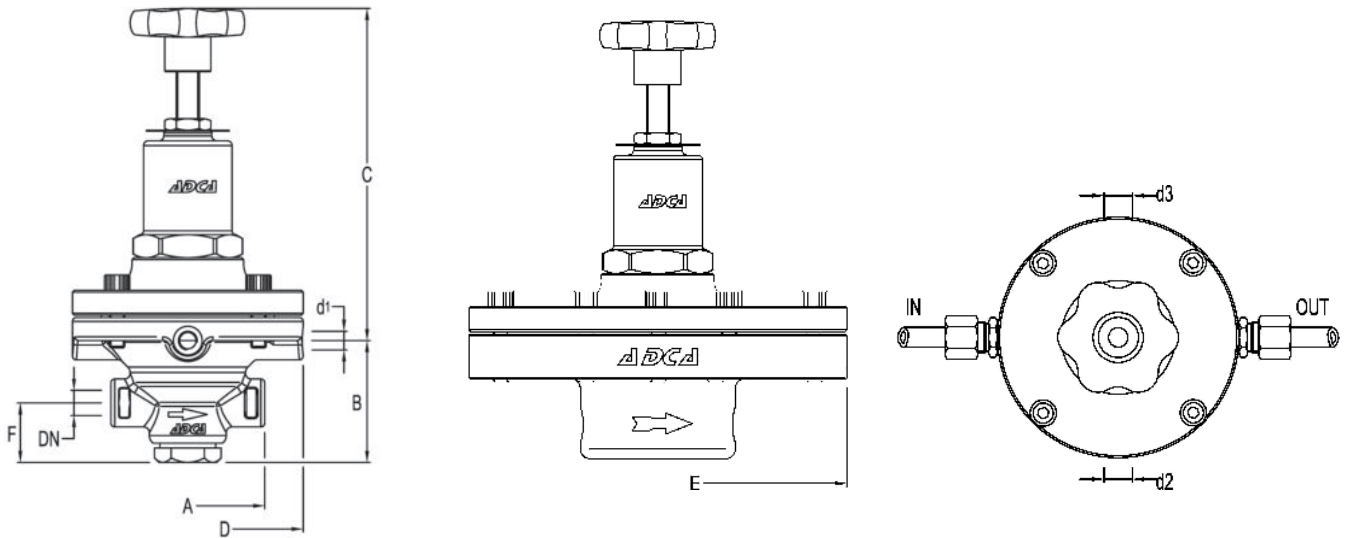

**DIMENSIONS (mm)**

SIZE	A	B	C	D	E *	F	d1 **	d2 ***	d3 ***	WEIGHT (kg)
1/4"	80	63,5	185	120	195	31	1/8"	1/4"	1/4"	4,8
3/8"	80	63,5	185	120	195	31	1/8"	1/4"	1/4"	4,8

\* Low pressure top (bar stock construction); \*\* Optional external sensing connection; \*\*\* Optional pressure gauge connections.  
Remark: all optional threaded connections are supplied in accordance with the main connections.

**MATERIALS**

POS. N°	DESIGNATION	MATERIAL
1	Valve body	AISI 316 / 1.4401; A351 CF8M / 1.4408
2	Plug	AISI 316 / 1.4401
3	* Gasket	Stainless steel / Graphite
4	* Strainer screen	AISI 304 / 1.4301
5	Gasket	Copper
6	* Spring	AISI 302 / 1.4300
7	* Valve head	AISI 420; EPDM; PTFE; etc.
8	* Pilot valve body	AISI 316 / 1.4401
9	* Pushrod	AISI 316 / 1.4401
10	* Diaphragm	AISI 301 / 1.4310
11	* Gasket	Stainless steel / Graphite
12	Top cover	A351 CF8 / 1.4308
13	Cover spring	A351 CF8 / 1.4308
14	Lower spring carrier	Brass
15	Upper spring carrier	Brass
16	* Adjustment spring	Spring steel
17	Spring id. plate	Aluminium
18	Locknut	Stainless steel A2-70
19	Handwheel	Plástico
20	Bolts	Stainless steel A2-70
21	Restrictor	Stainless steel A2-70

\* Available spare parts.

Remarks: All valves have a serial number. In case of non-standard valves this number must be supplied if spare parts are ordered.

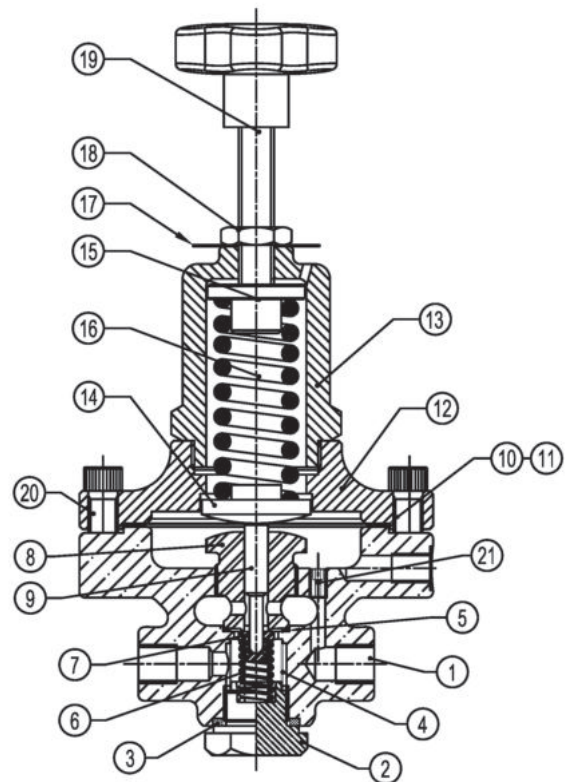

**REGULATING RANGES**

SPRING COLOUR	GREEN w/ 1 diaphragm	BLUE w/ 1 diaphragm	RED w/ 2 diaphragms	BLACK w/ 2 diaphragms
Regulating range	0,07 to 0,5 bar * 0,35 to 2 bar	1,5 to 5,5 bar	3,5 to 8,5 bar	7 to 17 bar

\* With special low pressure top assembled.

ORDERING CODES P7										
<b>Valve model</b>	P7SS	.	1	S	E	S	4	A	08	
P7SS – stainless steel pilot pressure reducing valve	P7SS									
<b>Regulating range</b>										
Green spring – 0,35 to 2 bar – single diaphragm			1							
Blue spring – 1,5 to 5,5 bar – single diaphragm			2							
Red spring – 3,5 to 8,5 bar – double diaphragm			3							
Black spring – 7 to 17 bar – double diaphragm			4							
Dome loaded – 0,35 to 4 bar – single diaphragm a)			6							
Dome loaded – 2 to 17 bar – double diaphragm a)			7							
<b>Application</b>										
Steam				S						
Gases				G						
<b>Seal material b)</b>										
Metal to metal					(1)					
EPDM					E					
PTFE					T					
FPM / Viton					V					
<b>Diaphragm</b>										
Standard diaphragm						S				
Low pressure diaphragm						L				
<b>Gauge port 1/4"</b>										
Without gauge ports							(1)			
Gauge port on the left side (relative to the flow direction)								4		
Gauge port on the right side (relative to the flow direction)									3	
Gauge ports on both sides										2
<b>Pipe connection</b>										
Female threaded ISO 7 Rp									A	
Female threaded NPT ASME B1.20.1										C
<b>Size</b>										
1/4"										08
3/8"										10
<b>Special valves / Extras</b>										
Full description or additional codes have to be added in case of non-standard combination.										E

(1) Omitted if a standard valve is requested.

a) The loading control pressure is approximately the same as the required downstream set-point pressure ( $\pm 0,2$  bar).

b) Valve limited to the materials' maximum operating temperature. Consult manufacturer for more details.

Remarks: The external sensing connection must be requested with the order, when required.